

Panasonic®

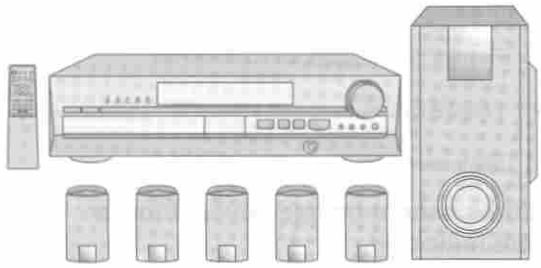

DVD Home Theater Sound System

Operating Instructions

Model No. **SC-HT70/SC-HT65**



Before connecting, operating or adjusting this product, please read these instructions completely.
Please keep this manual for future reference.

This unit responds to the region number information on DVDs. This unit can only play DVDs if the region number of the disc matches the region number of this unit.
See page 6 for details.

Dear Customer

Thank you for purchasing this product.
For optimum performance and safety, please read these instructions carefully.

System		SC-HT70	SC-HT65
Main unit		SA-HT70	SA-HT65
Speakers	Front, center and surround	SB-AFC80	SB-AFC80
	Subwoofer	SB-W70	SB-W70

CAUTION!

THIS PRODUCT UTILIZES A LASER.
USE OF CONTROLS OR ADJUSTMENTS OR PERFORMANCE OF PROCEDURES OTHER THAN THOSE SPECIFIED HEREIN MAY RESULT IN HAZARDOUS RADIATION EXPOSURE.
DO NOT OPEN COVERS AND DO NOT REPAIR YOURSELF. REFER SERVICING TO QUALIFIED PERSONNEL.

WARNING:

TO REDUCE THE RISK OF FIRE, ELECTRIC SHOCK OR PRODUCT DAMAGE, DO NOT EXPOSE THIS APPLIANCE TO RAIN, SPLASHING, DRIPPING OR MOISTURE.

CAUTION!

DO NOT INSTALL, OR PLACE THIS UNIT, IN A BOOKCASE, BUILT-IN CABINET OR IN ANOTHER CONFINED SPACE. ENSURE THE UNIT IS WELL VENTILATED. TO PREVENT RISK OF ELECTRIC SHOCK OR FIRE HAZARD DUE TO OVERHEATING, ENSURE THAT CURTAINS AND ANY OTHER MATERIALS DO NOT OBSTRUCT THE VENTILATION VENTS.

Only the U.S.A. and Canada

CAUTION:

TO PREVENT ELECTRIC SHOCK MATCH WIDE BLADE OF PLUG TO WIDE SLOT, FULLY INSERT.

For areas except the U.S.A. and Canada

CAUTION:

The AC voltage is different according to the area. Be sure to set the proper voltage in your area before use. (For details, please refer to page 10.)

DANGER	- VISIBLE AND INVISIBLE LASER RADIATION WHEN OPEN. AVOID DIRECT EXPOSURE TO BEAM. (FDA 21 CFR)
CAUTION	- VISIBLE AND INVISIBLE LASER RADIATION WHEN OPEN. AVOID EXPOSURE TO BEAM. (IEC60825-1)
ATTENTION	- RAYONNEMENT LASER VISIBLE ET INVISIBLE EN CAS D'OUVERTURE. EXPOSITION DANGEREUSE AU FAISCEAU.
ADVARSEL	- SYNLIG OG USYNLIG LASERSTRÅLING VED ÅBNING. UNDGÅ UDSÆTTELSE FOR STRÅLING.
VARO!	- AVAATTAESSA OLET ALLTTIINA NÄKTYVÄÄ JA NÄKYMÄTÖN LASERSÄTELYLLE. ÄLÄ KATSO SÄTEESEEN.
VARNING	- SYNLIK OCH OSYNLIG LASERSTRÅLNING NÄR DECKSELN ÄR ÖPPNAD. BETRÄKTA EJ STRÅLEN.
ADVARSEL	- SYNLIG OG USYNLIG LASERSTRÅLING NÄR DEKSEL ÅPNES. UNNGÅ EKSPONERING FOR STRÅLING.
VORSICHT	- SICHTBARE UND UNSICHTBARE LASERSTRÄHLUNG, WENN ABDECKUNG GEÖFFNET, NICHT DEM STRAHL AUSSETZEN.
注意	- 打开时有可能及不可见激光照射。避免对激光照射。
注	- ここを覗くと可能及び不可見のレーザー光が出ます。レーザー照射より、眼に当たらないでください。 RCL50223

(Inside of product)

Disc symbols used in these operating instructions

The functions you can use depend on the type of disc you play. These marks are used to indicate which type of disc is explained.



Feature can be used with DVD-Video



Feature can be used with video CD



Feature can be used with audio CD

Some features cannot be used even if these symbols are indicated.

THE FOLLOWING APPLIES ONLY IN THE U.S.A. AND CANADA



CAUTION: TO REDUCE THE RISK OF ELECTRIC SHOCK, DO NOT REMOVE SCREWS. NO USER-SERVICEABLE PARTS INSIDE. REFER SERVICING TO QUALIFIED SERVICE PERSONNEL.



The lightning flash with arrowhead symbol, within an equilateral triangle, is intended to alert the user to the presence of uninsulated "dangerous voltage" within the product's enclosure that may be of sufficient magnitude to constitute a risk of electric shock to persons.



The exclamation point within an equilateral triangle is intended to alert the user to the presence of important operating and maintenance (servicing) instructions in the literature accompanying the appliance.

Except for the U.S.A. and Canada

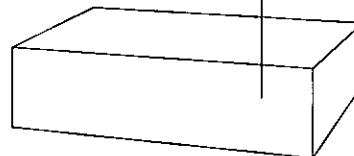

Back of product

Table of contents

Before use

PRECAUTIONS	4
Supplied accessories	5
Type of discs	5
Region numbers	6
DVD symbols	6
Concerning the remote control	7
Speaker set-up	8
Connections	10
Front panel controls	11

Preparations

Selecting TV screen type	13
---------------------------------------	----

Disc operations

Playing discs	14
Other methods of play	16
Using the resume function to restart play	16
Pause (Still picture)	16
Search function	16
Skip function	17
Frame-by-frame viewing	17
Slow-motion play	17
Repeat function	18
Marking a position	19
Disc skip	20
Using menus to play	20
Changing soundtracks	21
Changing subtitle language	22
Switching angles	22
Changing the picture quality for movie viewing (Cinema mode)	23
Starting play from a specific track	23
Random play	23
Using the Disc Manager	24
Program play	25
Using GUI screens	26
GUI icon descriptions	27

Radio operations

The radio: manual tuning	29
The radio: preset tuning	30
Automatic presetting	30
Selecting channels	30

Sound quality/sound field operations

Sound field	31
Sound field systems and effects you can enjoy with this unit ..	31
Enjoying sound with Dolby Digital	32
Enjoying sound with Dolby Pro Logic	32
Enjoying sound with SUPER SURROUND	34
To down mix to 2 channels	34
Using the seat position function (SEAT POSITION)	35
Using the center focus effect (CENTER FOCUS)	35
Sound Field Control effects (SFC)	36

Other functions

Timer function	37
Convenient functions	38
To mute the volume	38
To turn off the unit's display	38
To listen through headphones	38
Adjusting the bass	38
Using other equipment	39
Connecting other equipment	39
Outdoor antenna connections	39
Listening to an external source	40
Recording to other equipment	40
Using the remote control with other equipment	41
Operating a television	41
Operating a video deck	41
Changing the remote control code	42

Reference

Initial settings	43
Concerning discs	48
Glossary	49
Troubleshooting guide	50
Maintenance	52
When moving the unit	52
Product Service	52
Listening caution	52
Specifications	53
Warranty (Only for U.S.A.)	54
Servicenter List (U.S.A.)	55

PRECAUTIONS

Before using this unit please read these operating instructions carefully. Take special care to follow the warnings indicated on the unit itself as well as the safety suggestions listed below. Afterwards keep them handy for future reference.

Safety

- 1. Power Source** — The unit should be connected to power supply only of the type described in the operating instructions or as marked on the unit.
- 2. Polarization** — If the unit is equipped with a polarized AC power plug (a plug having one blade wider than the other), that plug will fit into the AC outlet only one way. This is a safety feature. If you are unable to insert the plug fully into the outlet, try reversing the plug. If the plug should still fail to fit, contact your electrician to replace your obsolete outlet. Do not defeat the safety purpose of the polarized plug.
- 3. Power Cord Protection** — AC power supply cords should be routed so that they are not likely to be walked on or pinched by items placed upon or against them. Never take hold of the plug or cord if your hand is wet, and always grasp the plug body when connecting or disconnecting it.
- 4. Nonuse Periods** — When the unit is not used, turn the power off. When left unused for a long period of time, the unit should be unplugged from the household AC outlet.

Installation

Environment

- 1. Outdoor Antenna Grounding** — If an outside antenna is connected to the receiver, be sure the antenna system is grounded so as to provide some protection against voltage surges and built-up static charges. Section 810 of the National Electrical Code, ANSI/NFPA No. 70-1990, provides information with respect to proper grounding of the mast and supporting structure, grounding of the lead-in wire to an antenna discharge unit, size of grounding conductors, location of antenna-discharge unit, connection to grounding electrodes, and requirements for the grounding electrode. See figure below.

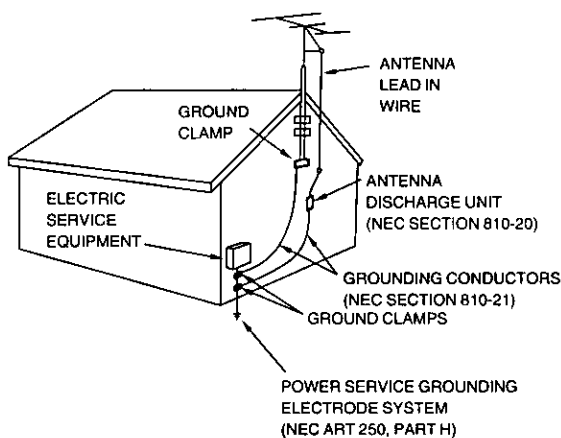

NEC—NATIONAL ELECTRICAL CODE

- 2. Water and Moisture** —Do not use this unit near water—for example, near a bathtub, washbowl, swimming pool, or the like. Damp basements should also be avoided.

- 3. Heat** —The unit should be situated away from heat sources such as radiators and the like. It also should not be placed in temperatures less than 5°C (41°F) or greater than 35°C (95°F).
- 4. Condensation** —Moisture may form on the lens in the following conditions...
 - immediately after a heater has been turned on.
 - in a steamy or very humid room.
 - when the unit is suddenly moved from a cold environment to a warm one.

If moisture forms inside this unit, it may not operate properly. To correct this problem, turn on the power and wait about one hour for the moisture to evaporate.

Placement

- 1. Ventilation** —The unit should be situated so that its location or position does not interfere with its proper ventilation. Allow 10 cm (4") clearance from the rear of the unit.
- 2. Foreign Material** —Care should be taken so that objects do not fall into and liquids are not spilled into the unit. Do not subject this unit to excessive smoke, dust, mechanical vibration, or shock.
- 3. Magnetism** —The unit should be situated away from equipment or devices that generate strong magnetic fields.
- 4. Stacking** —Do not place heavy objects, other than system components, on top of the unit.
- 5. Surface** —Place the unit on a flat, level surface.
- 6. Carts and Stands** —The unit should be used only with a cart or stand that is recommended by the manufacturer. The unit and cart combination should be moved with care. Quick stops, excessive force, and uneven surfaces may cause the unit and cart combination to overturn.
- 7. Wall or Ceiling Mounting** —The unit should not be mounted to a wall or ceiling, unless specified in this operating instructions.



Maintenance

(See page 52 for details.)

Clean the cabinet, panel and controls with a soft cloth lightly moistened with mild detergent solution. Do not use any type of abrasive pad, scouring powder or solvent such as alcohol or benzine.

Service

- 1. Damage Requiring Service** — The unit should be serviced by qualified service personnel when:
 - (a) The AC power supply cord or the plug has been damaged; or
 - (b) Objects have fallen or liquid has been spilled into the unit; or
 - (c) The unit has been exposed to rain; or
 - (d) The unit does not appear to operate normally or exhibits a marked change in performance; or
 - (e) The unit has been dropped, or the enclosure damaged.
- 2. Servicing** — The user should not attempt to service the unit beyond that described in the operating instructions. All other servicing should be referred to an authorized service personnel. *In the U.S.A., contact the Panasonic Customer Call Center at 1-800-211-7262, or e-mail consumerproducts@panasonic.com, or web site (<http://www.panasonic.com>). In Canada, contact Panasonic Canada Inc. Customer Care Centre at 1-800-561-5505, or web site (www.panasonic.ca), or an authorized Servicentre nearest you.*

Supplied accessories

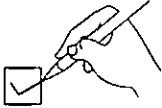

Please check and identify the supplied accessories.
(Only for the U.S.A.)
To order accessories contact
1-800-332-5368 or web site
(<http://www.panasonic.com>).

- AC power supply cord 1 pc.

For the U.S.A. and Canada
(RJA0065-A)

For others
(RJA0019-2K)

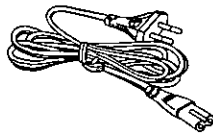
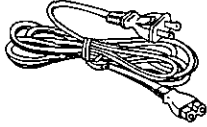

- AM loop antenna set (RSA0012) 1 pc.

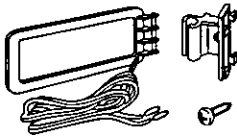

- FM indoor antenna (RSA0006-J) 1 pc.



- Video connection cable (RJL1P016B15A) 1 pc.



- Remote control transmitter (EUR7502X10) 1 pc.

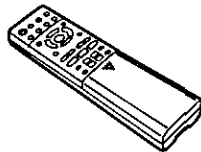

- Batteries 2 pcs.

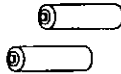

- Speaker feet (RFA0631A-K) 25 feet
Replacements sold in sets of 4.

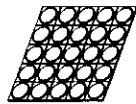

- Speaker stickers 1 sheet (2 sets)
One set is extra. The sheet cannot be purchased separately.

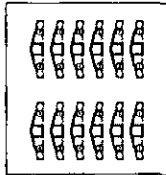

- Power plug adaptor (SJP5213-2) 1 pc.
For areas except the U.S.A. and Canada



Use numbers indicated in parentheses when asking for replacement parts.

Type of discs

This system can playback discs bearing any of the marks:



This system does not have a DTS decoder so it cannot play audio encoded with DTS.

This system can not play the following discs

- DVD with an unsuitable region number
- DVD-Audio
- PAL system discs
- DVD-ROM
- DVD-R
- DVD-RAM
- +RW
- DVD-RW
- DIVX Video Disc
- CD-ROM
- VSD
- CDV
- CD-G
- CVD
- SACD
- SVCD
- Photo CD etc.

MP3 playback

You can use this unit play MP3 format audio recorded for personal use with a computer, etc., onto CD-R or CD-RW. Play may not be possible in some cases due to the condition of the recording. Discs recorded using MP3 differ to CDs in the following ways.

• Structure of the disc (example)

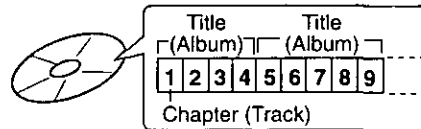

• Starting play from a selected chapter

Press the numbered buttons and press [ENTER].

Example: Chapter 23 [2]→[3]→[ENTER]

(Pressing [≥10]/[ENTER] is unnecessary.)

• Repeat play

You can use chapter repeat or title repeat.

• Program play, random play and disc manager

You cannot use program play, random play and disc manager.

Note

• Not compatible with multi-session recordings

If you record MP3 onto CD-R/CD-RW over a number of sessions, this unit can play only the recordings made in the first session.

• Recordings will not necessarily be played in the order you recorded them.

The recordings will be reordered according to their titles: numbers in numerical order first, upper case in alphabetical order next, and lower case in alphabetical order last.

• If you play an MP3 track that includes still picture data, it will take some time before the music itself starts playing and the elapsed time will not be displayed during this time.

Even after the track starts, the correct play time will not be displayed.

Before use



Region numbers

Region numbers are allocated to DVD players and software according to where they are sold. DVDs can be played on this unit if their region number is the same or includes the same number, or if the DVD is marked "ALL". Confirm the region number for this unit before choosing discs. The number for this unit is indicated on the rear panel.

Example

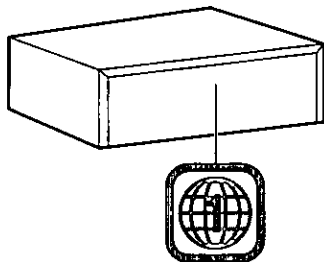

For the U.S.A., Canada, and units with PX printed on the outer packaging

- The region number of this unit is "1".
- You can play DVDs marked with labels containing "1" or "All".



For Latin America

- The region number of this unit is "4".
- You can play DVDs marked with labels containing "4" or "All".



DVD symbols

Symbols shown on DVD jackets

These are examples of the symbols shown on DVD jackets.

<p>Region number</p>	<p>Region numbers are allocated to DVD players and software according to where they are sold.</p> <ul style="list-style-type: none"> • Latin America: [4] • The U.S.A., Canada and others: [1] <p>DVDs can be played on this unit if their region number is the same or includes the same number, or if the DVD is marked "ALL".</p>
<p>Audio recording method</p>	<p>The left side tells you which method was used for recording. This example is of a disc that was recorded using Dolby Digital 5.1 channel surround.</p>
<p>Multi-angle</p>	<p>This indicates the software was filmed from multiple angles at the same time. The number tells you the number of angles.</p>
<p>Screen size</p>	<p>These symbols tell you which screen format was used to film the software.</p>

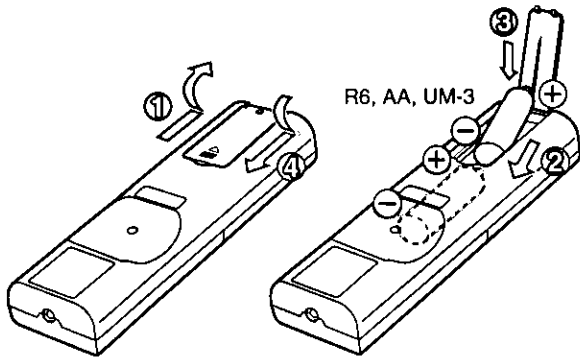
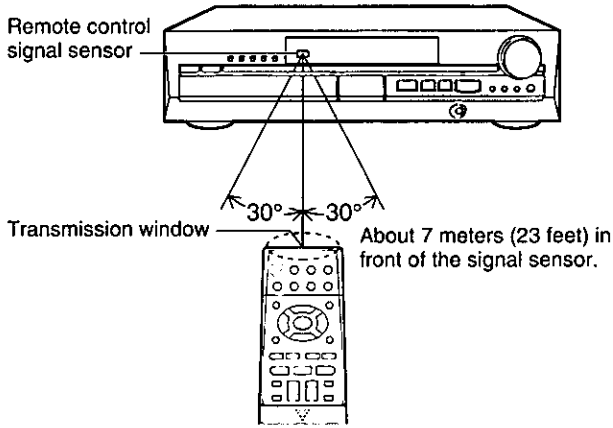
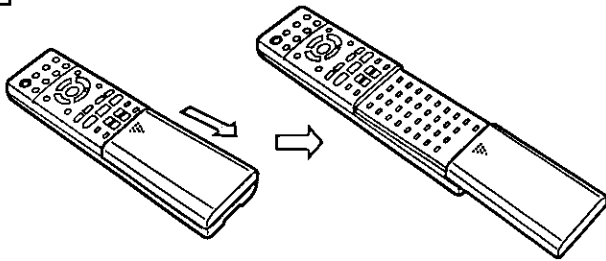
A**B****C**

Concerning the remote control

A Battery installation

Use of batteries

- Align the poles (+ and -) properly when inserting the batteries. Press in and down towards the minus end.
- Do not mix old and new batteries, or batteries of different types.
- Do not recharge ordinary dry cell batteries.
- Do not heat or disassemble the batteries. Do not allow them to contact flame or water.
- Remove the batteries if the unit is not to be used for a long time.
- Do not keep together with metallic objects such as necklaces.
- Do not use batteries if the covering has been peeled off.
- Do not use rechargeable type batteries.

Mishandling of batteries can cause electrolyte leakage which can damage items the fluid contacts and may cause a fire. If electrolyte leaks from the batteries, consult your dealer. Wash thoroughly with water if electrolyte comes in contact with any part of your body.

B Correct method of use

Operation notes

- Do not place obstacles between the remote control signal sensor and remote control unit.
- Do not expose the remote control signal sensor to direct sunlight or to the bright light of a fluorescent light.
- Take care to keep the remote control signal sensor and end of the remote control unit free from dust.
- If this system is installed in a rack with glass doors, the glass doors' thickness or color might make it necessary to use the remote control a shorter distance from the system.

To prevent damage

- Never place heavy items on top of the unit.
- Do not disassemble or reconstruct the unit.
- Do not spill water or other liquids into the unit.

C How to open the remote control

Before use

Speaker set-up

Refer also to "Speaker set-up", a separate guide included with these operating instructions.

1 Attach the stickers

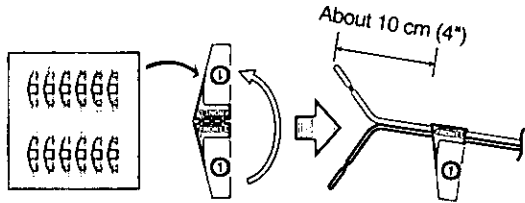

Attach the stickers to the speaker cords.

- ① - ⑤: Attach stickers 1 to 5 to the cords of the 5 small speakers (2× front, 2× surround, and 1× center: SB-AFC80).
- ⑥: Attach sticker 6 to the cord of the large speaker (subwoofer: SB-W70).

2 Attach the rubber feet

The small speakers can be set-up either standing or lying down. Attach these rubber feet to prevent vibration causing the speakers to move or fall over.

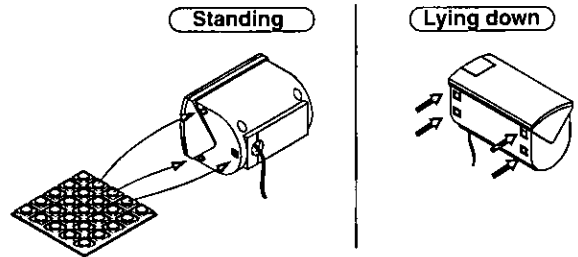

3 Position the speakers

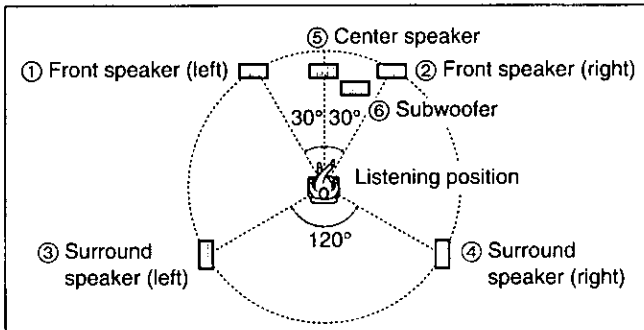

① - ⑥: Position the speakers as indicated in the diagram using the stickers as a guide.

The front, center, and surround speakers should be placed at approximately the same distance from the listening position. The angles in the diagram are approximate.

- Place the front left and right speakers (①, ②) either side of the television.
- Place the center speaker (⑤) near the television, above or below it.
- Place the surround speakers (③, ④) either side of the listening position, or slightly to the rear, about 1 meter (3 feet) higher than ear level.
- Put the subwoofer (⑥) near the television, on the floor or a sturdy shelf so that it won't cause vibration.

Note

- Vibration caused by the center speaker can disrupt the picture if it is placed directly on the television. Put the center speaker on a rack or shelf.
- A superwoofer is located on the side of the subwoofer. Leave 10-cm (4") clearance for it to be effective.

4 Connect the speakers to the unit

Speaker cords

- Connect the cords so the numbers on the stickers match the numbers under the terminals.
- Connect the gray cords with the blue stripe ⊖ to the blue terminals.
- Connect the gray cords without stripes ⊕ to the gray terminals.
- Connect the subwoofer's red cord ⊕ to the red terminal and the black cord ⊖ to the black terminal.
- Ensure the wires of the cords are fully inserted so they do not touch each other and short circuit.

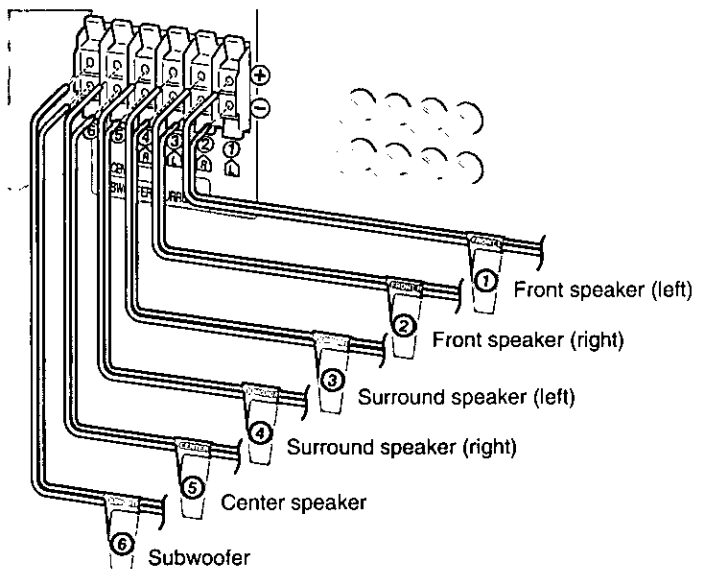
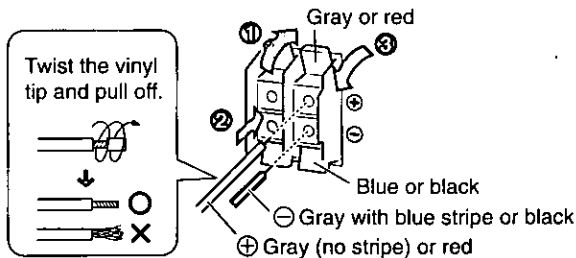

Note

- After you have completed set-up and connection, wind the excess cord and keep together with string.
- Set the speakers up on an even surface to prevent them from falling. Take proper precautions to prevent the speakers from falling if you cannot set them up on an even surface.
- The speaker nets cannot be removed.
- Keep your speakers at least 10 mm (13/32") away from the system for proper ventilation.

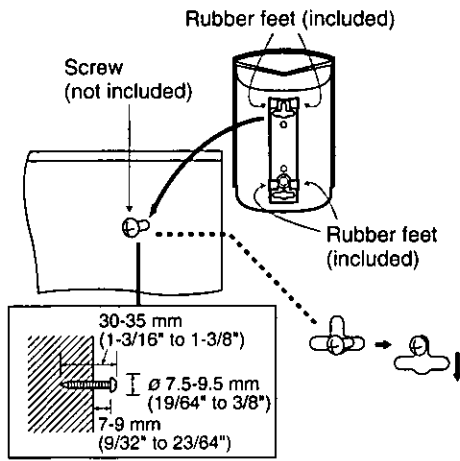
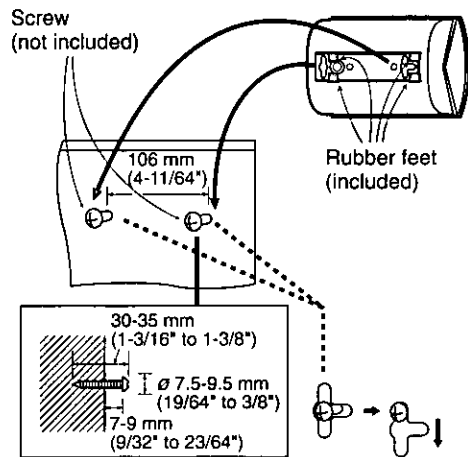
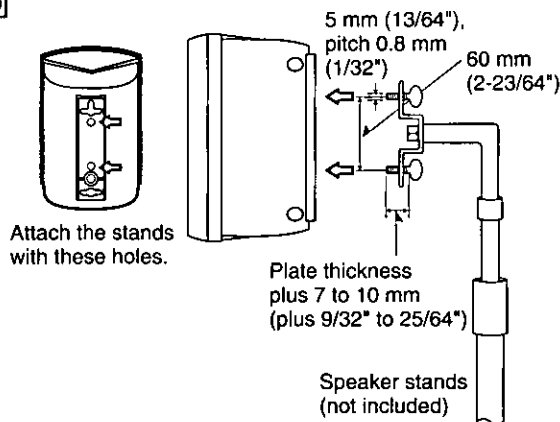
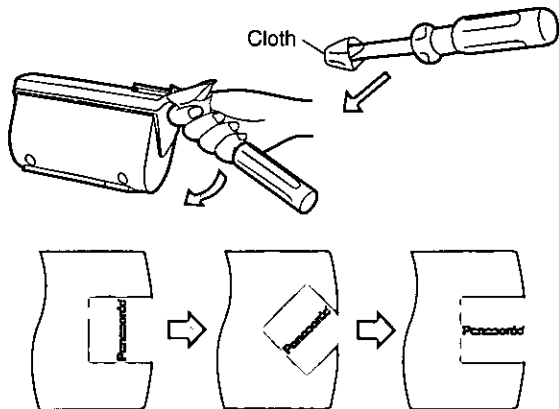
A**B****C****D****Speaker set-up****Attaching to a wall****A** To attach vertically**B** To attach horizontally

Attach four rubber feet to each speaker, ensuring they do not cover the holes.

Note

The surface you attach the speakers to must be able to support over 5 kg (11 lb.) per screw.

C**Attaching to speaker stands****Note**

Ensure the following conditions are met when you purchase your speaker stands.

- Observe the diameter and length of the screws and the distance between screws as shown in the diagram.
- The stands must be able to support over 5 kg (11 lb.).
- The stands must be stable even if the speakers are in a high position.

D**Moving the brand plate**

You can rotate the brand plate if you choose to set up the small speakers horizontally.

(Prevent damage to the plate by wrapping the end of the screwdriver with cloth.)

Insert the screwdriver under the plate and lift it. Rotate the plate to the required position.

If irregular coloring occurs on your television

These speakers are designed to be used close to a television, but the picture may be affected with some televisions and set-up combinations.

If this occurs, turn the television off for about 30 minutes.

The television's demagnetizing function should correct the problem.

If it persists, move the speakers further away from the television.

Notes on speaker use

- You can damage your speakers and shorten their useful life if you play sound at high levels over extended periods.
- Reduce the volume in the following cases to avoid damage.
 - When playing distorted sound.
 - When the speakers are receiving howling from a microphone or record player, noise from FM broadcasts, or continuous signals from an oscillator, test disc, or electronic instrument.
 - When adjusting the sound quality.
 - When turning the unit on or off.

Positioning for best effect

How you set up your speakers can affect the bass and the sound field. Note the following points.

- Place speakers on flat secure bases.
- Placing speakers too close to floors, walls, and corners can result in excessive bass. Cover walls and windows with thick curtain.

Caution

- Use the speakers only with the recommended system. Failure to do so may lead to damage to the amplifier and/or the speakers, and may result in the risk of fire. Consult a qualified service person if damage has occurred or if you experience a sudden change in performance.
- Do not attempt to attach these speakers to walls using methods other than those described in this manual.

*Before use***9**

RQT5775

Connecting the indoor antennas, television, and power

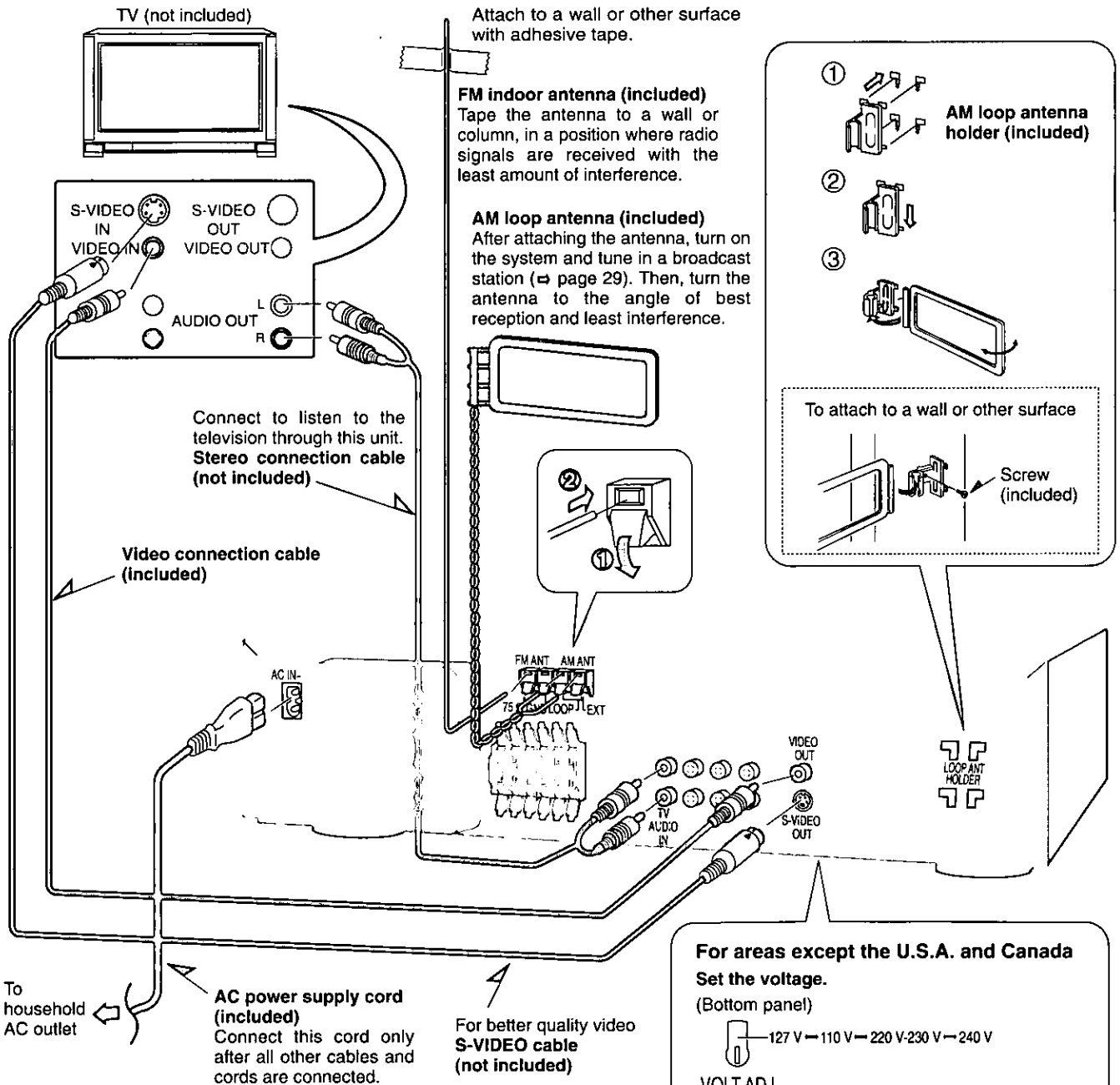

Note

The included AC power supply cord is for use with this unit only. Do not use it with other equipment.

Note

Make video connections from this unit directly to your television. The picture may not be displayed correctly on your television if connections are made through a video deck or a combination TV/VCR due to the copy guard.

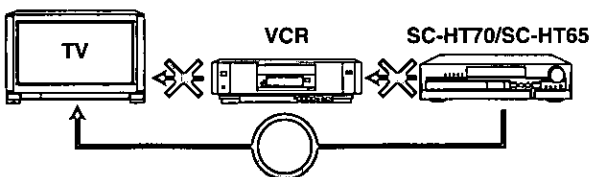

Front panel controls

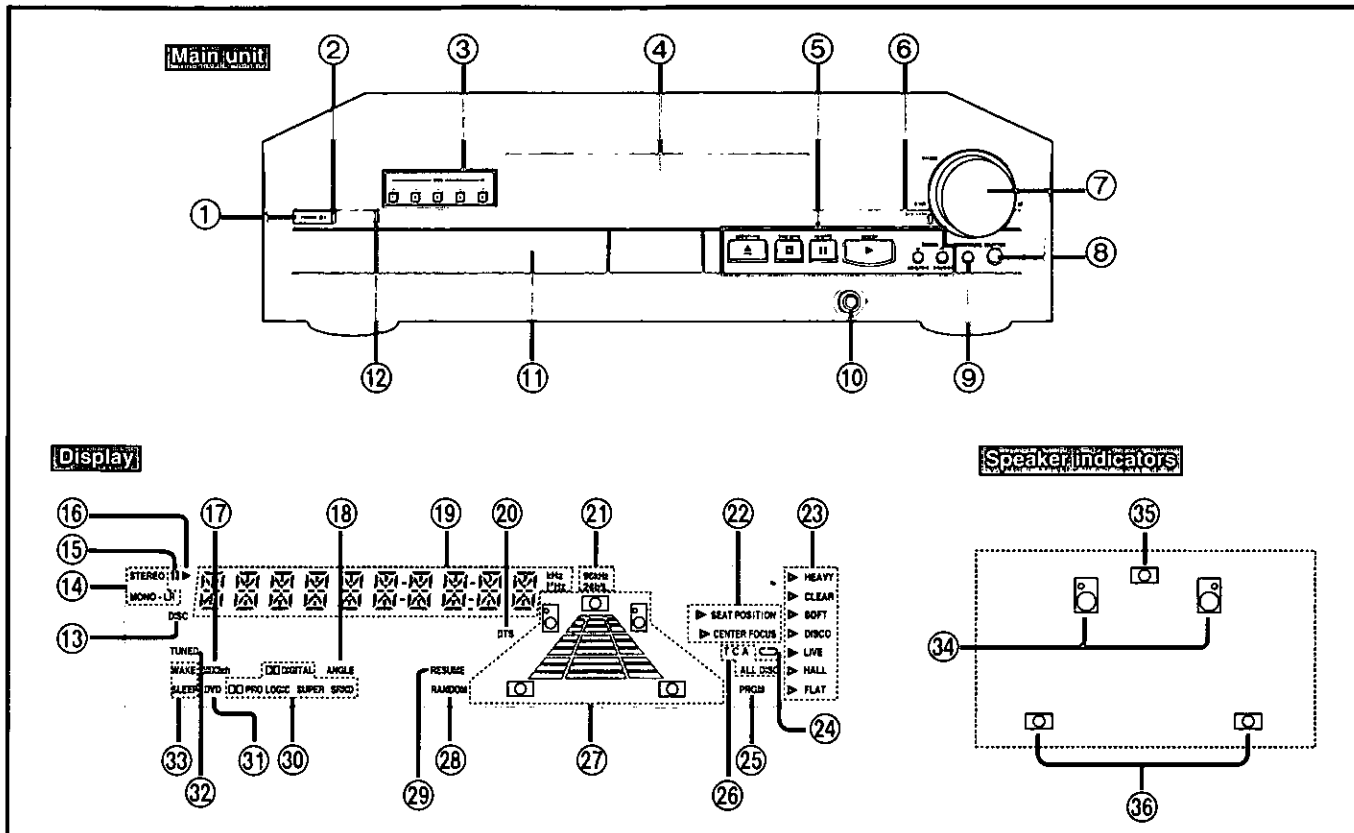

No.	Name	Ref. page
-----	------	-----------

Main unit

- ① **Standby/on switch (POWER ⏻/⏻)**
Press to switch the unit from on to standby mode or vice versa. In standby mode, the unit is still consuming a small amount of power.
- ② **Standby/on indicator**
When the unit is connected to the AC mains supply, this indicator lights red in standby mode and lights green when the unit is turned on.
- ③ **Disc select buttons (DISC 1-5)** 14
- ④ **Display**
- ⑤ **Basic operation buttons**
- ⑥ **Dolby Digital indicator (DD DIGITAL)** 32
- ⑦ **Volume control (VOLUME)** 15, 29
- ⑧ **Input select button (SELECTOR)** 14
- ⑨ **Subwoofer level button (SUBWOOFER LEVEL)** 38
- ⑩ **Headphones jack (PHONES)** 38
- ⑪ **Disc tray**
- ⑫ **Wake timer indicator (WAKE)** 37

Display

- ⑬ **Disc indicator**
- ⑭ **Stereo/mono indicator** 29
- ⑮ **Pause (Still picture) indicator** 16
- ⑯ **Play indicator** 15
- ⑰ **MIX 2ch indicator** 34

No.	Name	Ref. page
-----	------	-----------

- ⑱ **Angle indicator** 22
- ⑲ **General display**
- ⑳ **DTS indicator**
Lights when a disc with DTS is loaded.
- ㉑ **DVD disc signal indicator** 15
- ㉒ **Surround effect indicators** 35
- ㉓ **SFC mode indicators** 36
- ㉔ **Repeat indicator** 18
- ㉕ **Program indicator** 25
- ㉖ **Track/Chapter/All disc indicators** 24
- ㉗ **Speaker indicators**
- ㉘ **Random indicator** 23
- ㉙ **Resume indicator** 16
- ㉚ **Sound field system indicators** 32, 34
- ㉛ **DVD disc indicator** 15
Lights when DVD is loaded.
- ㉜ **Radio indicator** 29
- ㉝ **Timer indicators** 37

Speaker indicators

- ⑳ **Front speakers**
- ㉞ **Center speaker**
- ㉟ **Surround speakers**

Lights when sound is actually coming from the speaker.

Before use

Remote control

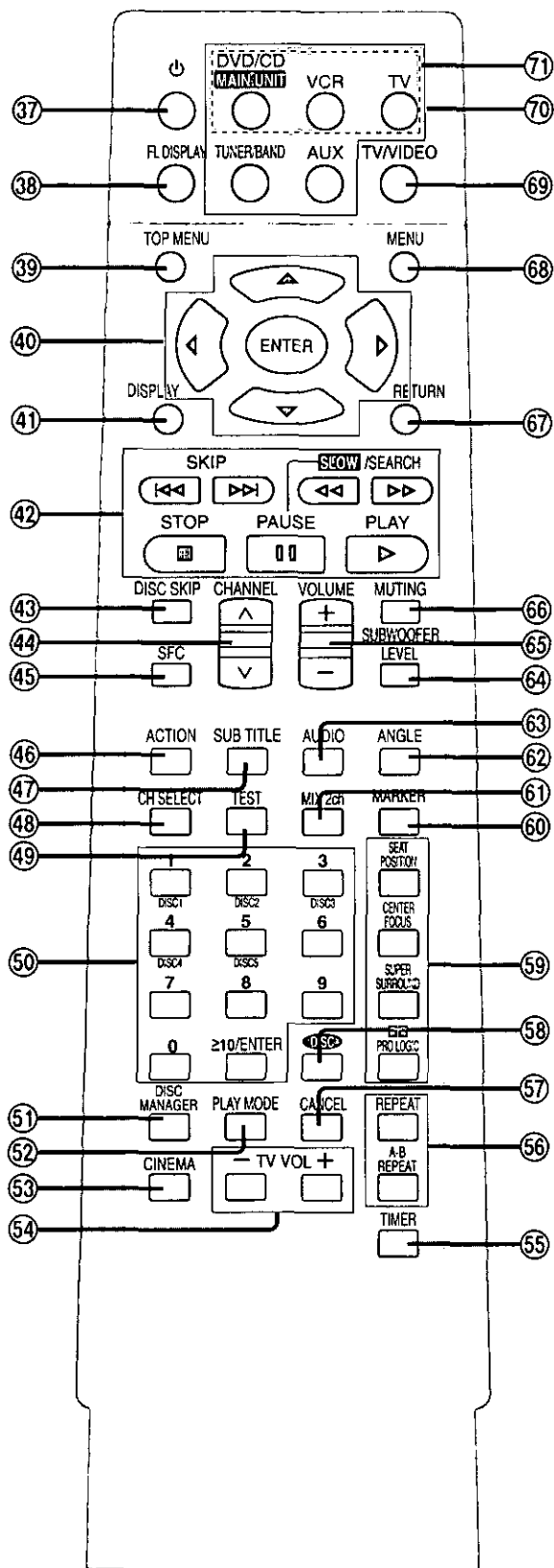

No.	Name	Ref. page
-----	------	-----------

- 37 Standby/on switch (⏻)
- 38 FL display button (FL DISPLAY) 38
- 39 Top menu button (TOP MENU) 20
- 40 Cursor and enter buttons
- 41 GUI display button (DISPLAY) 26
- 42 Basic operation buttons
- 43 Disc skip button (DISC SKIP) 20
- 44 Channel up/down button (CHANNEL \wedge , \vee) 30, 41
- 45 Sound field control button (SFC) 36
- 46 Initial settings button (ACTION) 13, 43
- 47 Subtitle language select button (SUB TITLE) 22
- 48 Speaker channel select button (CH SELECT) 33
- 49 Test button (TEST) 33
- 50 Numbered buttons and ≥ 10 /enter button (1-9, 0, ≥ 10 /ENTER)
- 51 Disc manager button (DISC MANAGER) 24
- 52 Play mode button (PLAY MODE) 23, 25
- 53 Cinema button (CINEMA) 23
- 54 TV volume up/down buttons (- TV VOL +) .. 41
- 55 Timer button (TIMER) 37
- 56 Repeat buttons (REPEAT, A-B REPEAT) 18
- 57 Cancel button (CANCEL) 19, 25
- 58 Disc button (DISC) 14, 23
- 59 Sound field and effect buttons 32-35
- 60 Marker button (MARKER) 19
- 61 2ch down mix button (MIX 2ch) 34
- 62 Angle button (ANGLE) 22
- 63 Soundtrack language select button (AUDIO) 21
- 64 Subwoofer level button (SUBWOOFER LEVEL) 38
- 65 Volume button (VOLUME +, -) 33
- 66 Muting button (MUTING) 38
- 67 Return button (RETURN) 13, 26, 43
- 68 Menu button (MENU) 20
- 69 TV/video select button (TV/VIDEO) 41
- 70 Input select buttons (AUX, TUNER/BAND, DVD/CD, TV, VCR)
TUNER/BAND button is also used to switch radio bands.
- 71 Equipment buttons and indicators
Select the equipment you want to operate.
Press [DVD/CD] to operate this unit.
Press [VCR] to operate a video cassette recorder.
Press [TV] to operate a television.

These buttons light for a few seconds to indicate the remote control mode.

Selecting TV screen type

Remote control only

Change the setting to suit the aspect ratio of your television.

The menu language is set to English, but you can change it other languages (⇒ Display—Menu Language, pages 43–45).

Preparation

- Turn on the television and switch the video-input mode on the television to suit the connection.

1 Press [DVD/CD] to select “DVD/CD” as the source.
The unit automatically comes on.

2 Press [ACTION] to display the initial settings screen on the television.

3 Press [◀] or [▶] to select the video settings tab.

4 Press [Δ] or [∇] to select “TV Aspect” and press [ENTER].

5 Press [Δ] or [∇] to select the option and press [ENTER].

• 4:3 Pan&Scan (Factory setting)

Select if you have a regular television and to view 16:9 software* in the pan and scan style (⇒ page 47).



• 4:3 Letterbox

Select if you have a regular television and to view 16:9 software in the letterbox style (⇒ page 47).



• 16:9

Select if you have a widescreen television.

※ 16:9 software prohibited from being shown in the pan and scan style will appear in the letterbox style despite the setting here.

The video settings screen is shown.

6 Press [ACTION].

To return to the previous screen

Press [RETURN].

For your reference

DVDs are recorded in a variety of aspect ratios. You can change the way software is shown on a regular television (4:3) with the above operation. If you have a widescreen television (16:9), use the television's picture modes (⇒ page 47).

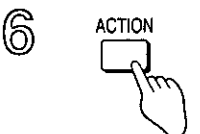
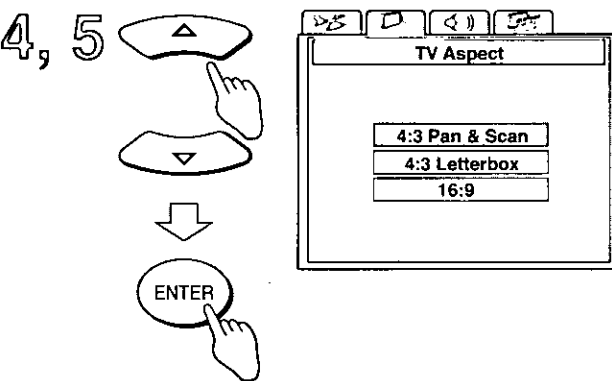
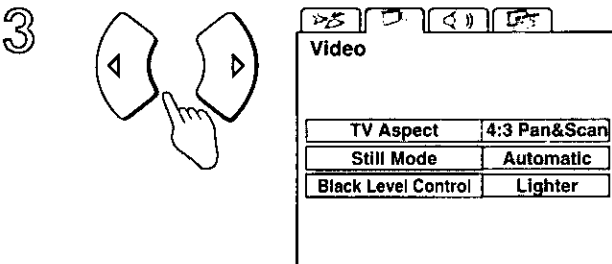
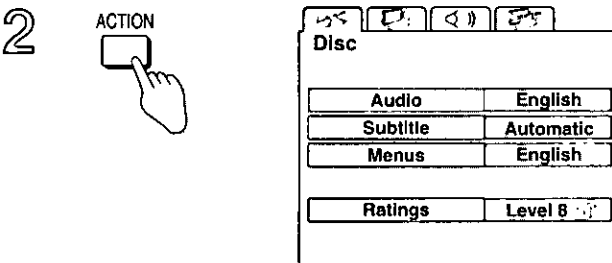
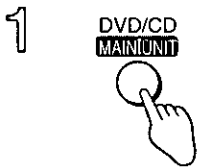
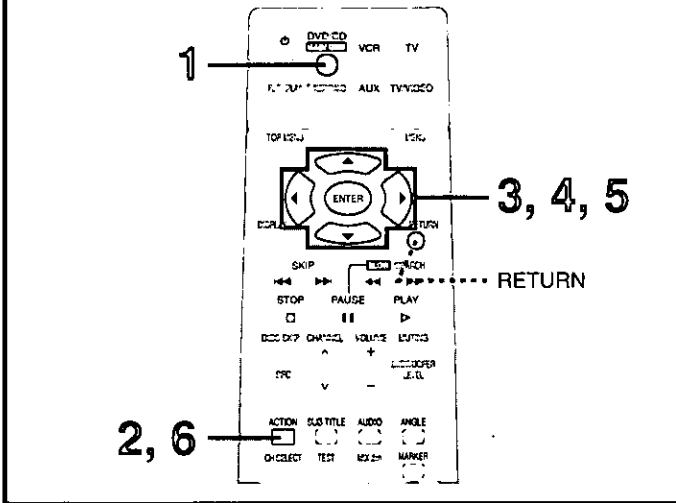

Before use, Preparations



Playing discs

DVD **VCD** **CD**

Preparation

- Turn the television on.
- Switch the video input mode on the television to suit the type of connection you have made (e.g., VIDEO 1).
- Press [POWER ϕ /I] to turn the unit on.

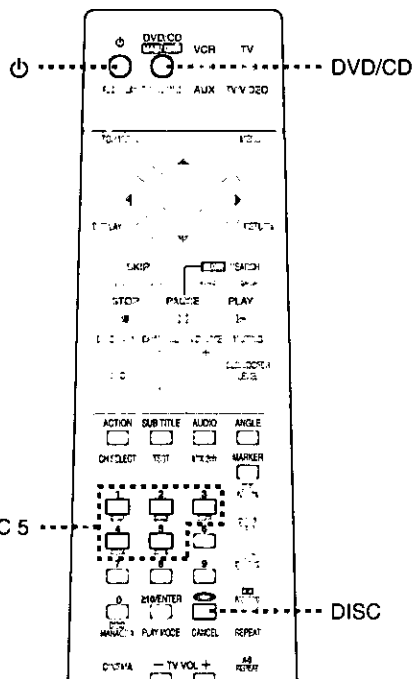
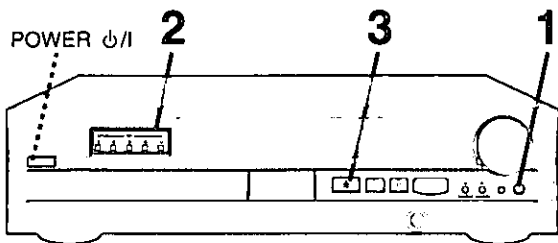

1 Press [SELECTOR] to select "DVD/CD" as the source.

The source changes each time you press the button on the main unit.

DVD/CD → FM → AM → TV → VCR → AUX

Remote control: Press [DVD/CD].

2 Press [DISC 1]–[DISC 5] to select a tray.

The indicator lights.

Play starts if a disc is in the tray. (One-touch play)

"NO DISC" is displayed if there is no disc in the tray.

Remote control:

Press [DISC] and then the numbered button corresponding to the required tray.

3 Press [Δ OPEN/CLOSE] to open the tray and insert a disc.

Press again to close and start play. Use this button to open the tray when removing discs.

(Continued on next page)

1 SELECTOR

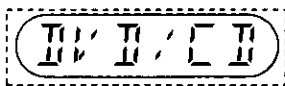

2 DISC

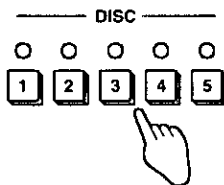

3 OPEN/CLOSE

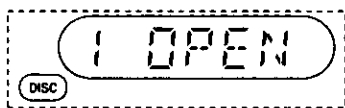

Label must face upward.

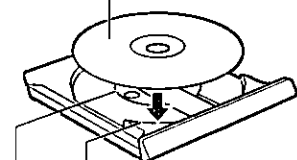

Guide for 12 cm discs

Guide for 8 cm discs

Playing discs

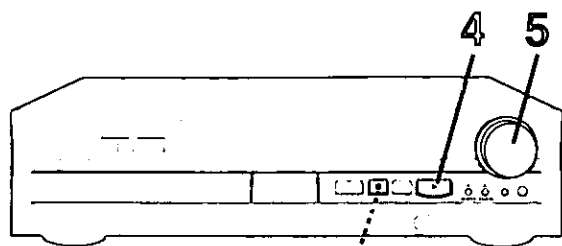

4 If play doesn't start after step 3
Press [▷] to start play.

Remote control: Press [PLAY ▷].

If a menu appears on the television:

- Use the cursor buttons to highlight a title and press [ENTER] on the remote control.
- Use the numbered buttons to select a title.
 For 10 or over
 To select 10: [≥10/ENTER] → [1] → [0]
 To select 11: [≥10/ENTER] → [1] → [1]

If the menu continues

Press [◀◀] or [▶▶] on the remote control.
 Buttons actually used depend on the disc.

[Note]

Menu items on video CD with playback control (PBC) (⇒ page 49) can only be selected with the numbered buttons.

5 Adjust the volume.

Remote control: Press [VOLUME (+ or -)].

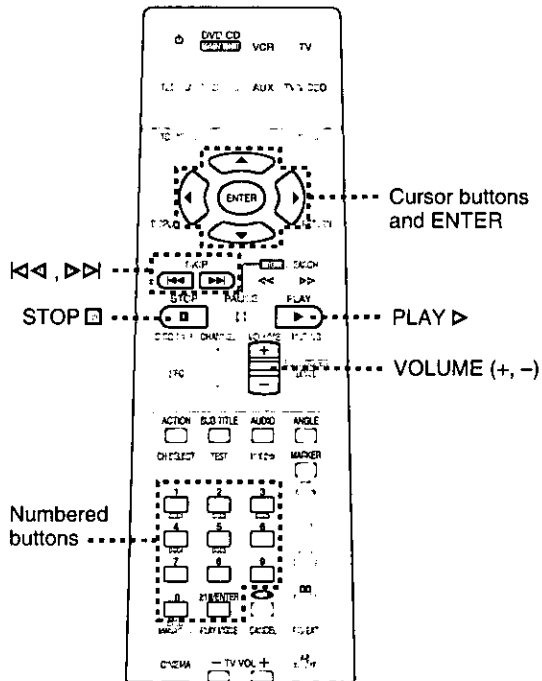

To stop the discs

Press [◻].

Remote control: Press [STOP ◻].

Resume function is activated (⇒ page 16).

“⊘” appears on the TV

This means the operation is not allowed at that time.

4

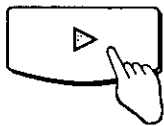

Lights during play.

Lights when 96 kHz 24 bit LPCM is detected.

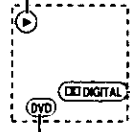

Lights if disc is DVD.

Lights when Dolby Digital is detected.

5

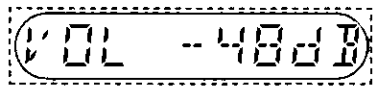
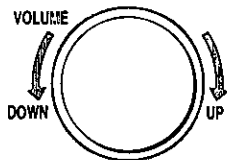

-- dB (MIN)  0 dB (MAX)

This unit can play CD-DA and video CD format audio CD-R and CD-RW that have been finalized* upon completion of recording.

It may not be able to play some CD-R or CD-RW due to the condition of the recording.

*Finalizing is a process that enables CD-R/CD-RW players to play audio CD-R and CD-RW.

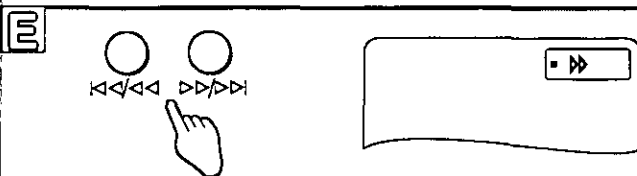
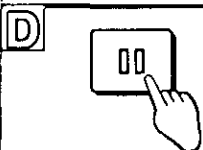
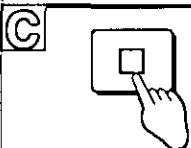
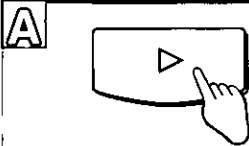
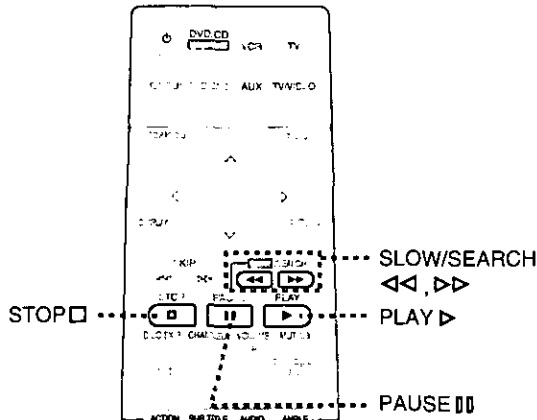
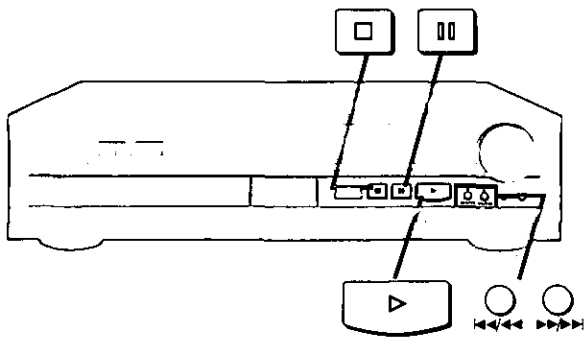

Other methods of play

DVD CD

Using the resume function to restart play

If you press [] or [STOP] during play, the unit remembers the position.

A To restart play from that point
Press [] while "RESUME" is lit.
 Remote control: Press [PLAY >].

B To review the chapters up to the point where you stopped play (DVD only)

The message "Press PLAY to Preview Chapters" appears for a few seconds before the resume function is activated after pressing [].

Press [] while this message is on the screen and the beginning portions of each chapter up to the current one are played.

Remote control: Press [PLAY >].

Full play resumes from the point where you stopped play.

C To cancel the resume function
Press [] while "RESUME" is lit.
 Remote control: Press [STOP].

Note

- The position is saved even if the unit is turned off.
- Resume is canceled if the disc tray is opened or if you change discs.
- Resume does not work if the disc's play time is not displayed.
- Chapter preview is not possible with some DVDs.
- Chapter preview may not be activated if you were watching chapter 1.

D Pause (Still picture)

Press [] during play.

Remote control: Press [PAUSE].

To resume play
 Press [] or [PLAY >].

E Search function

Press and hold [<<<<<] or [>>>>>] during play.

The speed increases if you press and hold the button. There are five speeds.

<<<<< : Backward

>>>>> : Forward

Remote control: Press [SLOW/SEARCH (<<< or >>>)].

Each press increases the speed of the search.

To resume play
 Press [] or [PLAY >].

For your reference

- Sound will be heard at speed one when searching forwards. You can turn this sound off if required (DVD, VCD only). (= "Audio during Search", page 44)
- Sound will be heard at all speeds when playing audio CDs.
- If pressed while playing a video CD with PBC, you may return to a menu screen.

Other methods of play

A Skip function

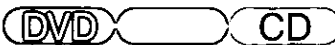

Press [**⏮**] or [**⏭**] to skip tracks (⇒ page 49) on CDs and Video CDs, and chapters/titles (⇒ page 49) on DVD video.

Remote control: Press [SKIP ⏮] or [SKIP ⏭].

⏮ : Backward

⏭ : Forward

- Each press increases the number of skips.
- The first skip backwards takes you to the beginning of the current track or chapter.

Note

If pressed while a video CD menu is on the screen, you may return to the previous menu.

B Frame-by-frame viewing

Remote control only



While paused

Press the cursor buttons [**⏪**] or [**⏩**].

⏪ : Backward

⏩ : Forward

- The frame changes each time you press a button.
- The frames change in succession if you press and hold the button.
- The frames also advance if you press [**⏸**] on the main unit or [PAUSE ⏸] on the remote control.

To resume play

Press [**▶**] or [PLAY ▶].

Note

You cannot move backwards with video CD.

C Slow-motion play Remote control only



While paused

Press [**SLOW/SEARCH** (⏪ or ⏭)].

⏪ : Backward

⏭ : Forward

Each press increases the speed of the slow motion. There are five speeds.

To resume play

Press [**▶**] or [PLAY ▶].

Note

You cannot move backwards with video CD.

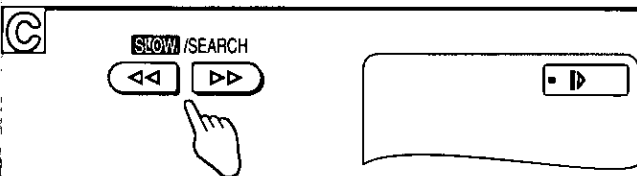
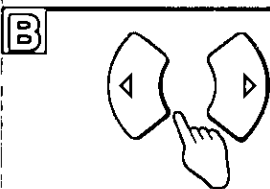
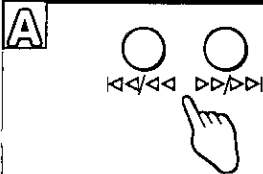
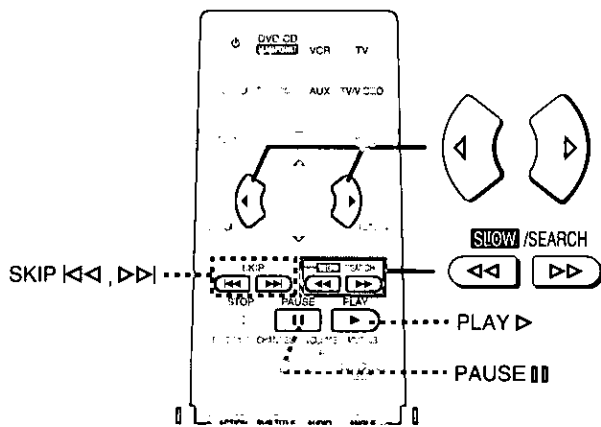
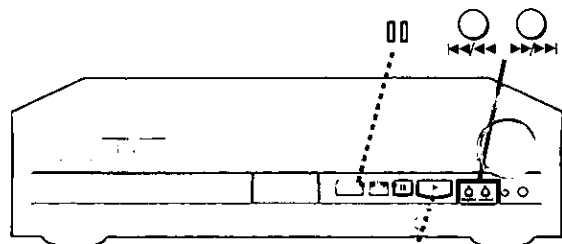

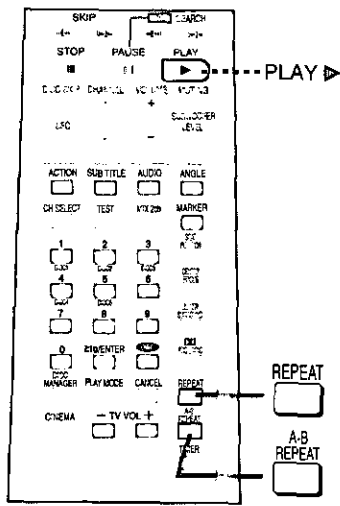

Other methods of play

Repeat function Remote control only



A Repeating chapters, titles, and tracks

Press [REPEAT] during play.

Each time you press the button;

- DVD
 - Ⓐ "C" (CHAPTER REPEAT): Chapters repeated.
 - Ⓑ "T" (TITLE REPEAT): Titles repeated.
 - Ⓒ "OFF" (REPEAT OFF): Repeat mode canceled.
- Video CD/CD
 - Ⓐ "A": Repeat entire disc contents.
 - Ⓑ Original display: Repeat mode canceled.

To cancel repeat play

Press [REPEAT] until "OFF" appears on the TV or "OFF" disappears from the unit's display.

Note

Repeat play does not work with some DVDs. It also doesn't work with interactive DVDs and video CDs with playback control.

To repeat only your favorite tracks

Video CD and CD only

- ① Program the tracks you want (⇒ page 25).
- ② Press [PLAY ▶].
- ③ Press [REPEAT] to display "A".

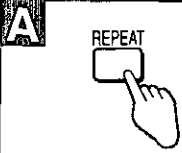

DVD

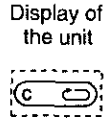
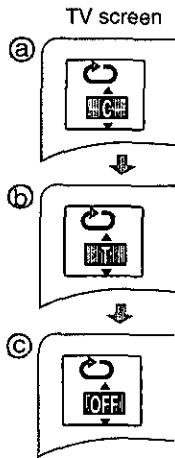

VCD, CD

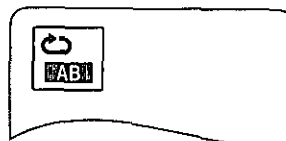
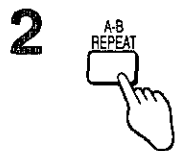
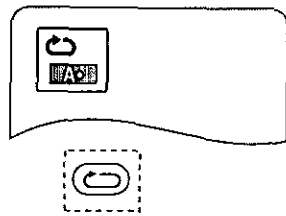
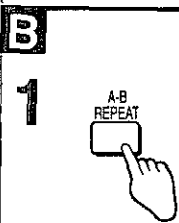
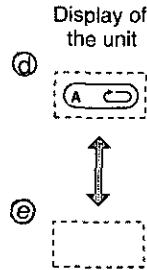

B Repeating a specific section (A-B REPEAT)

- 1 Press [A-B REPEAT] during play at the starting point (A).
- 2 Press [A-B REPEAT] at the finishing point (B).

To cancel A-B repeat play

Press [A-B REPEAT] until "A-B" is displayed.

Note

- This feature cannot be used if the play time for the DVD is not displayed.
- The player automatically determines the end of a title or track as point B.
- Subtitles may not appear between A and B.
- A-B repeat is canceled when you stop play.

A Marking a position (Remote control only)



This feature allows you to mark a specific point on a disc so you can return to it easily at a later time. There are five markers available.

It only works if the elapsed playing time of the disc you are playing is shown on the unit's display.

1 Press [MARKER] during play.
The marker display appears.

2 Press [ENTER] at the point you want to mark.

To mark another position

3 ① Press [◀] or [▶] to change markers.

② Press [ENTER].

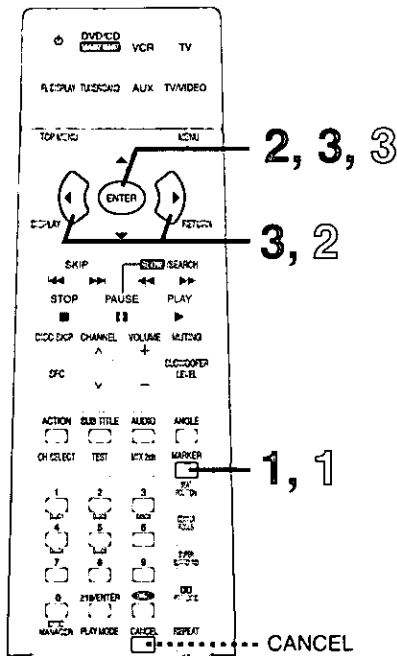

A

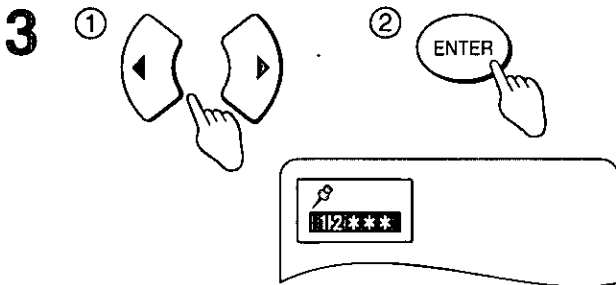
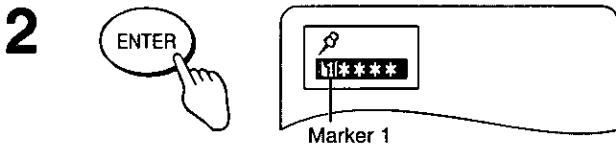
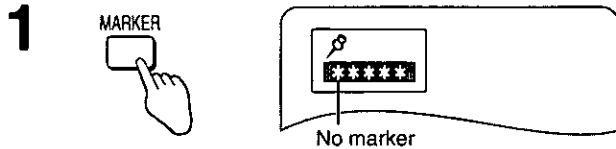

B

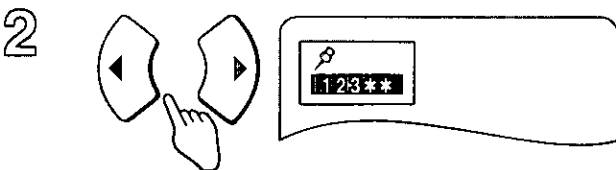
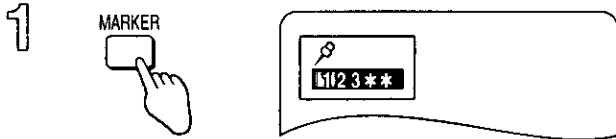

B Recalling a marked position

1 Press [MARKER].
The marker display appears.

2 Press [◀] or [▶] to highlight the required marker.

3 Press [ENTER] to recall the position.

To clear a marker

① Press [MARKER].

② Press [◀] or [▶] to highlight the marker you want to clear and press [CANCEL].

Note:

- The markers only work with the current disc.
- This feature can not be used with some DVDs or with video CDs with PBC.
- Some subtitles may fail to appear around the marker (DVD).
- Markers are cleared when the unit is turned off or the disc is removed or changed.

Other methods of play

A Disc skip (remote control only)



Press [DISC SKIP].

Play starts from the beginning of the disc in the next tray.
You will skip to tray 1 when the current tray is 5.

[Note]

[DISC SKIP] does not work during program and random play or while the disc manager is on.

B Using menus to play Remote control only



By calling up menus during play, you can start from a specific title or chapter.

Menu content depends on the disc. These operating instructions describe the basic steps.

1 Press [TOP MENU] or [MENU].

A menu screen is displayed.

(Press again to return to what you were watching with some discs.)

2 Select an item with the cursor buttons and press [ENTER] to confirm the selection.

You can select items with the numbered buttons with some discs.

Repeat it when another menu is shown.

DVDs can have several menus. The menu displayed by pressing [TOP MENU] may be different to the menu displayed by pressing [MENU].

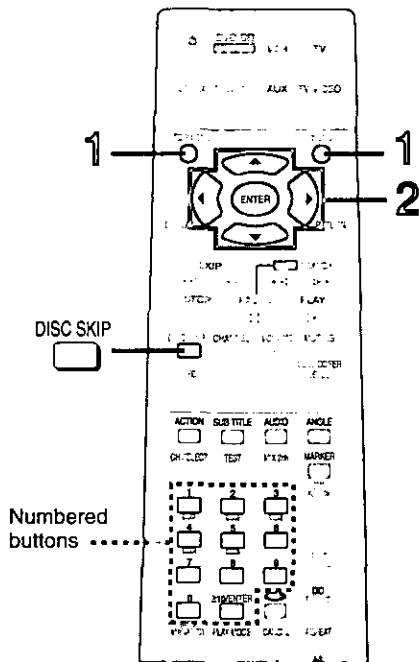
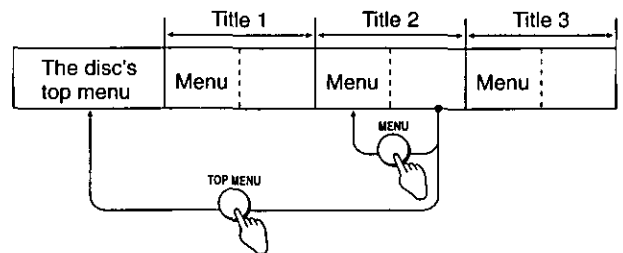

A



B

1



2

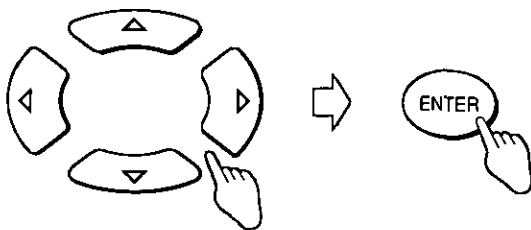

Other methods of play

A Changing soundtracks Remote control only

DVD

Some DVDs have more than one soundtrack recorded on them, such as multiple languages, and you can change soundtracks during play.

Press [AUDIO] during play.

The sound track display appears.

The number changes each time you press the button.

The number can also be changed with the cursor buttons (Δ or ∇) or the numbered buttons.

See page 27 for a key to language abbreviations.

Note

- You can only select languages or sound formats if they have been recorded on the disc you are playing.
- You can also make language settings before play with the "Audio" menu (⇒ page 44). (Some discs are designed to start in a certain language despite any changes you make to the unit's menus.)
- Some discs allow changes to soundtracks only by using the disc's menus.
- "—" or "—" is displayed instead of the language number in circumstances such as when no language is recorded on the disc.

B Using this feature with karaoke discs

You can do the following with karaoke discs.

While playing a karaoke disc

- 1 Press [AUDIO].
- 2 Press the cursor buttons [\leftarrow], [\rightarrow] to highlight the illustrated icon.
- 3 Press the cursor buttons [Δ], [∇] to turn the vocals on or off.

DVD karaoke disc (Solo)

[OFF]: Vocal OFF

[ON]: Vocal ON

DVD karaoke disc (Duet)

[OFF]: Vocal OFF

[V1+V2]: Vocal 1, 2 ON

[V1]: Vocal 1 only ON

[V2]: Vocal 2 only ON

Actual displays depend on the disc.

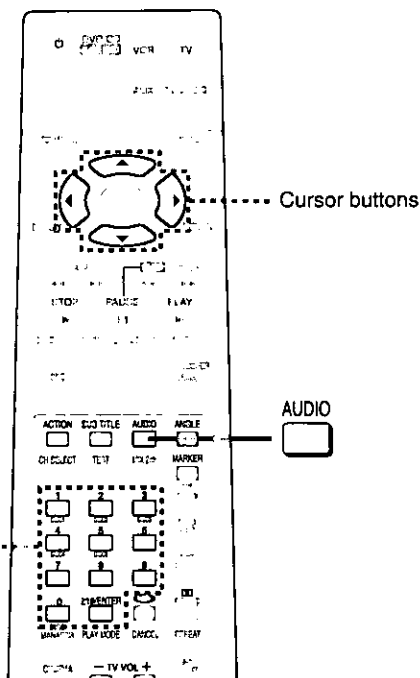

Numbered buttons

AUDIO

A

AUDIO

Soundtrack number

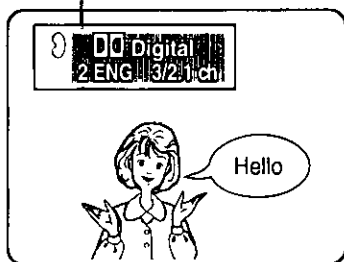

B



Other methods of play

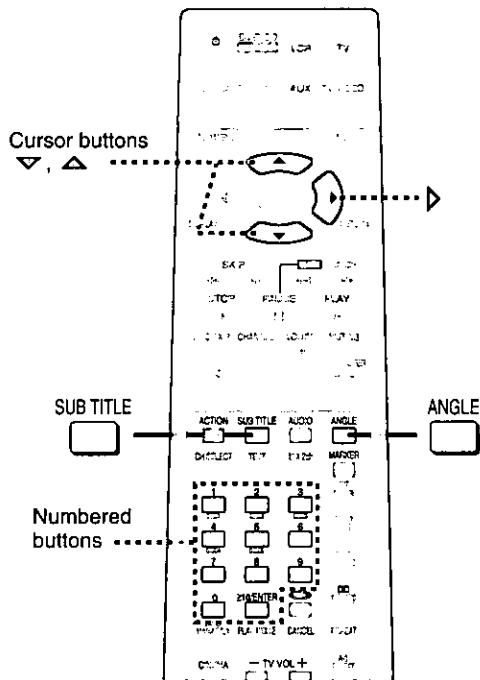

A Changing subtitle language

Remote control only



Some DVDs have more than one subtitle language recorded on them, and you can change language during play.

Press [SUB TITLE] during play.

The subtitle display appears.

The number changes each time you press the button.

The number can also be changed with the cursor buttons (▲ or ▼) or the numbered buttons.

See page 27 for a key to language abbreviations.

To clear/display the subtitles

1. Press [SUB TITLE].
2. Press [▶].
3. Press [▲] or [▼] to select "ON" or "OFF".

Note

- There may be a slight delay before subtitles are shown.
- You can only select languages if they have been recorded on the disc you are playing.
- You can also make language settings before play with the "Subtitle" menu (⇒ page 44). (Some discs are designed to start in a certain language despite any changes you make to the unit's menus.)
- Some discs allow changes to subtitle languages only by using the disc's menus.
- "—" or "—" is displayed instead of the language number in circumstances such as when no language is recorded on the disc.
- If the subtitles overlap closed captions recorded on discs, turn the subtitles off.

A

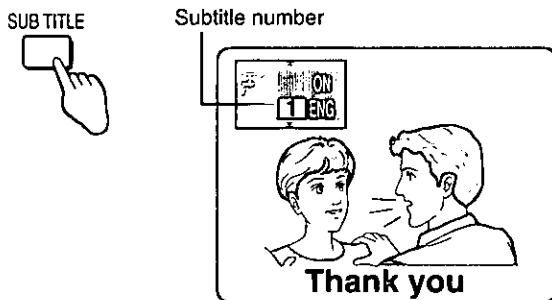

B

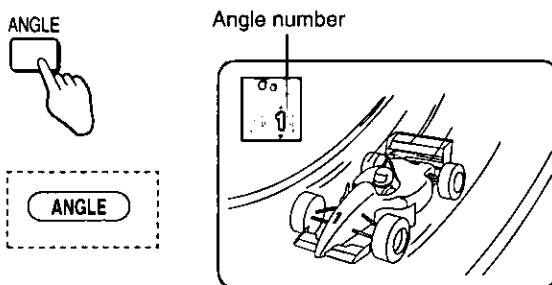

B Switching angles Remote control only



Some DVDs allow you to view the same scene from different angles.

Press [ANGLE] during play.

The angle display appears.

The number changes each time you press the button.

The number can also be changed with the cursor buttons (▲ or ▼) or the numbered buttons.

Note

- "ANGLE" lights up on the unit's display during scenes with multiple angles recorded to indicate this feature is available.
- Some discs allow you to set angles before multi-angle scenes are played. Read the instructions that come with the DVD.
- Some discs allow changes to angles only by using the disc's menus.

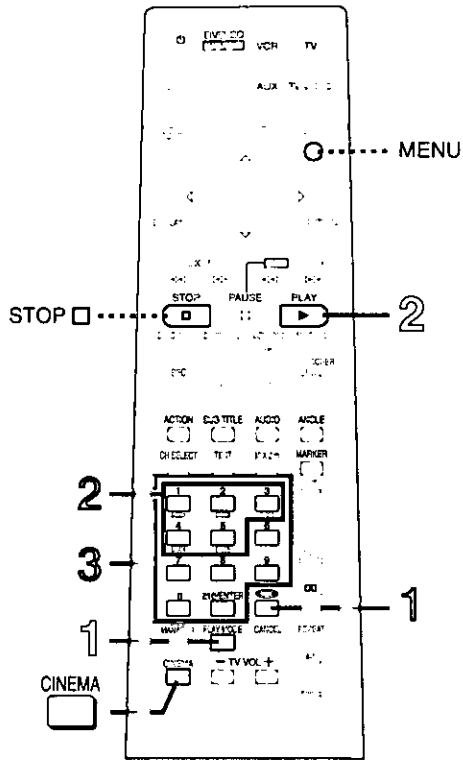

A

CINEMA

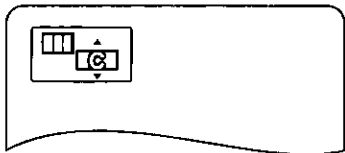

B

1



3

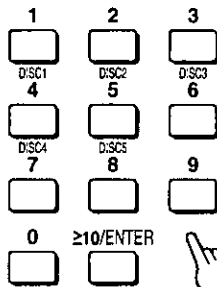

2

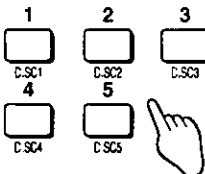

C

1

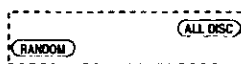

2



Other methods of play

A Changing the picture quality for movie viewing (Cinema mode) Remote control only



You can enjoy better pictures by changing the picture quality.

Press [CINEMA].

The cinema display appears on the screen.

Each time you press the button;

C (on) → N (off)

B Starting play from a specific track Remote control only



1 Press [DISC].

2 Press [DISC 1]–[DISC 5] to select a disc.

3 Wait for the disc to change and play to start

Press the numbered buttons to select the track.

For tracks numbered 10 or over, press [≥10/ENTER] then the two digits.

Track no. 10: [≥10/ENTER] → [1] → [0]

Track no. 25: [≥10/ENTER] → [2] → [5]

[NOTE]

- When playing video CDs with PBC, stop the disc then press [STOP □] again to cancel playback control, then select the track number. To restore playback control, stop the disc and press [MENU].
- There are some video CDs with PBC where this will not work.

C Random play Remote control only



This mode randomly plays the tracks on the current disc or all loaded discs once each.

1 While stopped **Press [PLAY MODE] to select "RANDOM" or "RANDOM ALL DISC".**

Each time you press the button;

PRGM → RANDOM → RANDOM ALL DISC → (off)

PRGM: Program play (⇒ page 25)

RANDOM: Randomly plays the tracks on the current disc.

RANDOM ALL DISC: Randomly plays the tracks on all discs.

2 Press [PLAY ▷].

To stop

Press [STOP □].

Random play is also canceled.

Other methods of play

Using the Disc Manager

[Remote control only]



The disc manager allows you to choose one track or disc to play or to play all five discs in succession.

- 1 While stopped
Press [DISC MANAGER] to select the desired method.

Each time you press the button;

- Ⓐ (1-TRACK): One track play
- Ⓑ (1-DISC): Plays one disc.
- Ⓒ (ALL-DISC): Plays five discs in succession.
- Ⓓ (NORMAL): Normal play (Off)

- 2 Select the disc and track.

When selecting a disc

Press [DISC] and [DISC 1]–[DISC 5].

When selecting a track

Press the numbered buttons.

For tracks numbered 10 or over, press [≥ 10 /ENTER] then the two digits.

Track no. 10: [≥ 10 /ENTER] → [1] → [0]

Track no. 25: [≥ 10 /ENTER] → [2] → [5]

You can also select the track by pressing [SKIP \lll] and [SKIP \ggg].

- 3 Press [PLAY \triangleright].

To cancel disc manager

Press [STOP \square].

To play a track or disc repeatedly

Press [REPEAT] during disc manager play.

Note

- You cannot use the disc manager while "RANDOM" or "PRGM" are on.
- When playing video CDs with playback control in the "A" or "ALL DISC" mode, you can play the disc without having to operate the disc's menus.
- The disc manager skips any DVDs that are loaded.

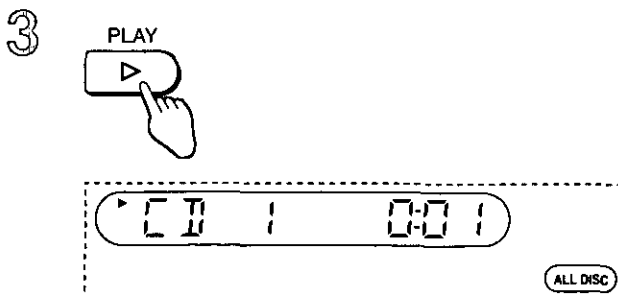
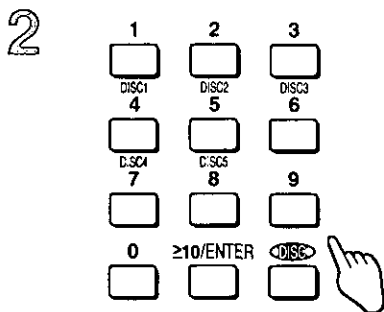
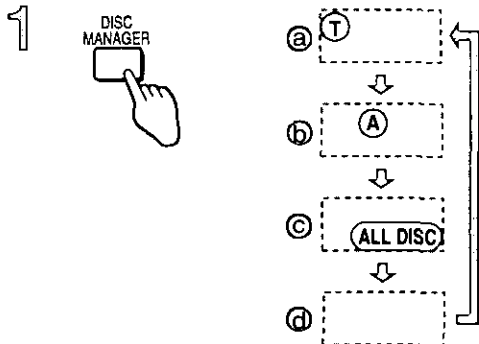
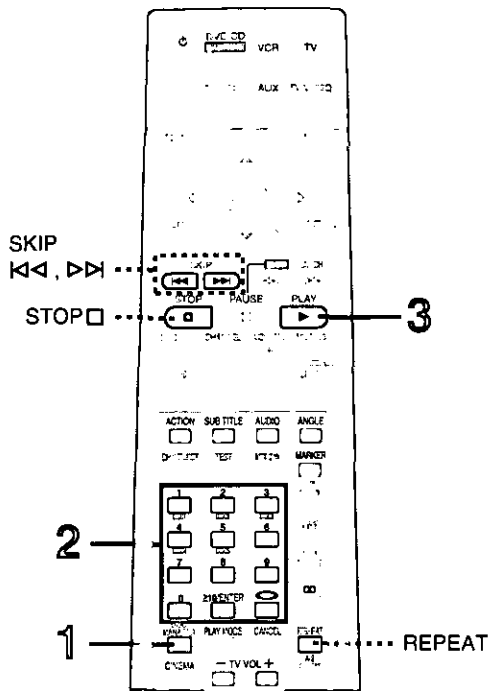

Other methods of play

Program play Remote control only

CD

You can select up to 24 tracks to play in the order you choose.

- 1 While stopped
Press [PLAY MODE] to select "PRGM".

Each time you press the button;
PRGM → RANDOM → RANDOM ALL DISC → (off)

- 2 ① Select the disc by pressing [DISC] and [DISC 1]–[DISC 5].
② Press the numbered buttons to select a track.

For tracks numbered 10 or over, press [≥10/ENTER] then the two digits.

Track no. 10: [≥10/ENTER] → [1] → [0]

Track no. 25: [≥10/ENTER] → [2] → [5]

Repeat these steps to program up to 24 tracks.

Step ① is unnecessary when programming tracks on the same disc.

- 3 Press [PLAY ▷].

To cancel program play

After stopping play, press [PLAY MODE] so "PRGM" goes out. The program contents are saved.

You can play the same program again if you press [PLAY MODE] so "PRGM" comes on.

To clear the last track

While stopped (Press [STOP □] to cancel the resume function if it is on.)

Press [CANCEL].

To clear the whole program

While stopped (Press [STOP □] to cancel the resume function if it is on.)

Press [STOP □] so "PRGM" goes out. "CLEAR" is displayed to indicate the program is cleared. If "CLEAR" is not displayed, start and stop play, then press [STOP □] again.

Note

- Discs and tracks the unit cannot find can be programmed but are canceled during play. This is also the case if you program DVD.
- The program mode is canceled (normal play mode is restored) when you turn the unit off, open the disc tray, or change the input source, but the program contents are saved.

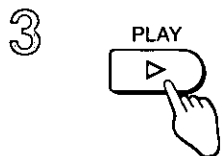
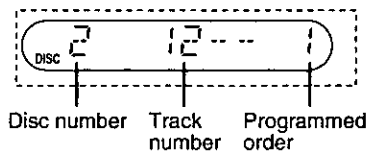
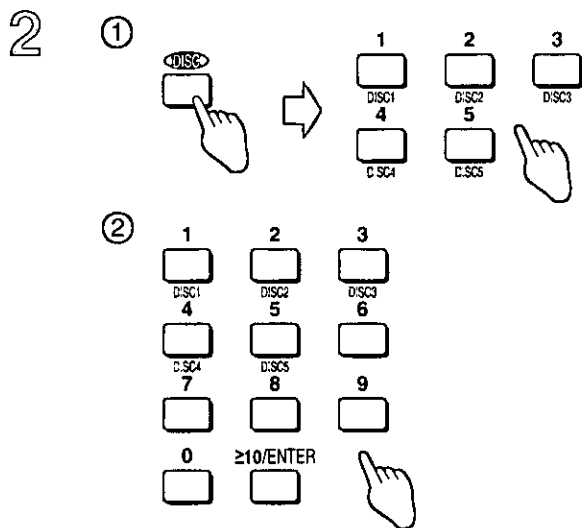
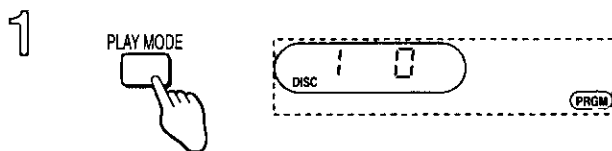
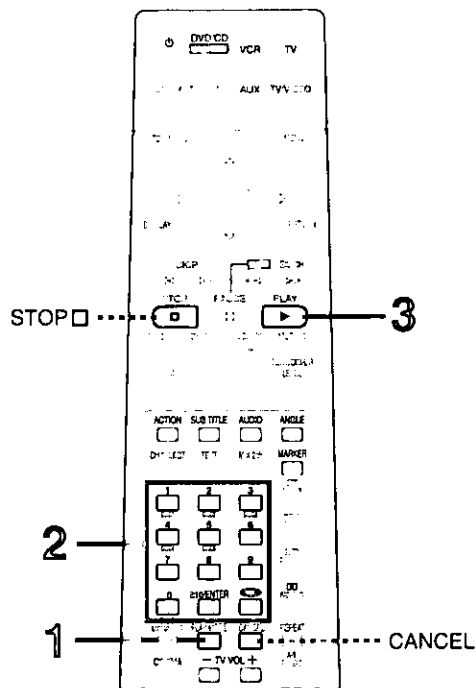

Remote control only



GUI (Graphic User Interface) are icons that contain information about the disc or unit. These icons allow you to perform operations by changing this information.

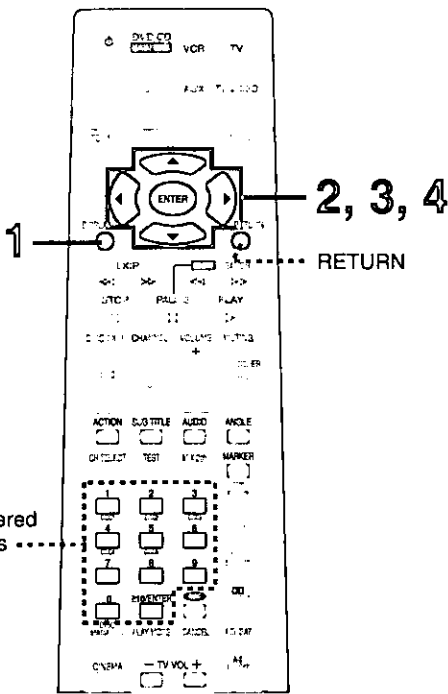

1 Press [DISPLAY].

Each time you press the button;

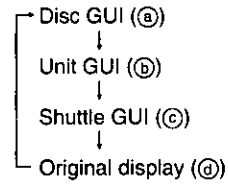

Actual GUI depend on the disc contents.

2 [Unit GUI] only

While the leftmost icon is highlighted Press [Δ] or [∇] to select the menu.

Each time you press the button;

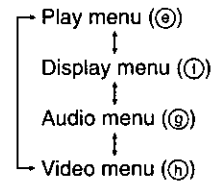

3 Press [◀] or [▶] to select the item.

4 Press [Δ] or [∇] to select the setting.

Items with "Δ" or "∇" above and below can be changed by [Δ], [∇]. Other items use different buttons. See pages 27 and 28 for details.

For your reference

- Some functions cannot be accessed from the stop mode (e.g. changing the soundtrack language).
- Press [ENTER] if the setting does not change after pressing [Δ], [∇].
- When numbers are displayed (e.g. title No.), the numbered buttons are also effective for the setting. When numbers are entered with the numbered buttons, press [ENTER] to register the setting.

To clear the GUI

Press [RETURN] until the GUI are cleared.

To change the position of the icons

You can lower the position of the icons on the screen if they are cut off for some reason.

1. Press [◀], [▶] to select the rightmost icon.



2. Press [Δ], [∇] to move the icon.

1 DISPLAY

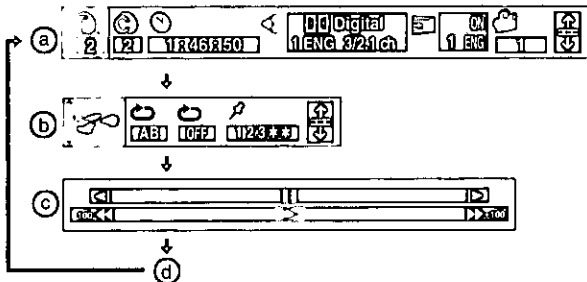

2

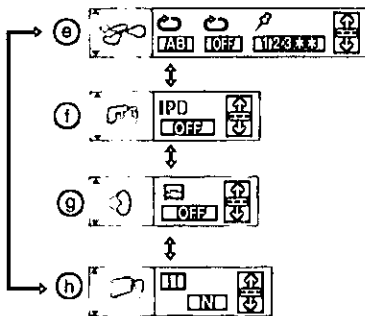

3

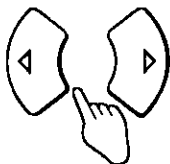



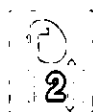





4



GUI icon descriptions

Disc GUI

Icon	Content
	Title number
	Chapter number
	Time (Select a position to start play by specifying a time with the numbered buttons.)
	Soundtrack language (See A at right for language abbreviations.)
	Audio signal type (See B at right for details.)
	(Karaoke DVD only) Karaoke vocal on/off Solo: OFF or ON Duet: OFF, V1 + V2, V1 or V2
	Subtitle language (See A at right for language abbreviations.)
	Subtitles on/off ON ↔ OFF
	Angle number

A Audio/Subtitle language

ENG: English	SVE: Swedish	CHI: Chinese
FRA: French	NOR: Norwegian	KOR: Korean
DEU: German	DAN: Danish	MAL: Malay
ITA: Italian	POR: Portuguese	VIE: Vietnamese
ESP: Spanish	RUS: Russian	THA: Thai
NLD: Dutch	JPN: Japanese	*: Others

B Signal type/data

LPCM/Dolby Digital: Signal type
 k (kHz): Sampling frequency
 b (bit): Number of bits
 ch (channel): Number of channels

Example:

3/2.1ch

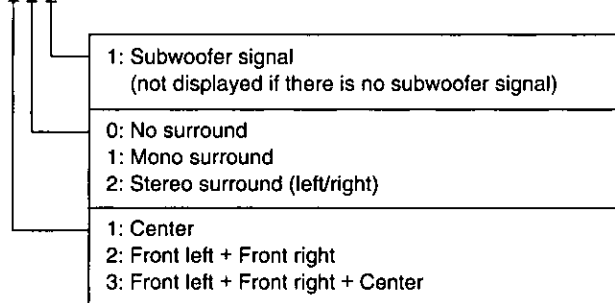

Unit GUI

Play menu



Icon	Content
	A-B repeat (⇒ page 18) [ENTER] (start point) → [ENTER] (finish point) To cancel [ENTER]
	Repeat play (⇒ page 18) C (Chapter) → T (Title) → OFF
	Marker (⇒ page 19) [ENTER] so the unit is ready to accept marks.
	To mark a position [ENTER] (at the desired point)
	To mark another position [◀], [▶] → [ENTER]
	To recall a marker [◀], [▶] → [ENTER]
	To erase a marker [◀], [▶] → [CANCEL]

Display menu



Icon	Content
	IPB display (⇒ page 49) Displays the picture type (I/P/B) in the still picture mode. ON ↔ OFF

Audio menu



Icon	Content
	(Dolby Digital, 3-channel or over only) Dialogue Enhancer Makes the dialogue in movies easier to hear. ON → OFF (Actual results depend on the disc.)

Video menu



Icon	Content
	Cinema mode (⇒ page 23) C: Cinema mode N: Normal mode

Shuttle GUI

Icon	Content
	Pause
	Slow-motion play ◀ : Backward ▶ : Forward
	Play
	Search ◀◀ : Backward ▶▶ : Forward

There are five speeds for both backward and forward slow-motion and search.

The radio: manual tuning

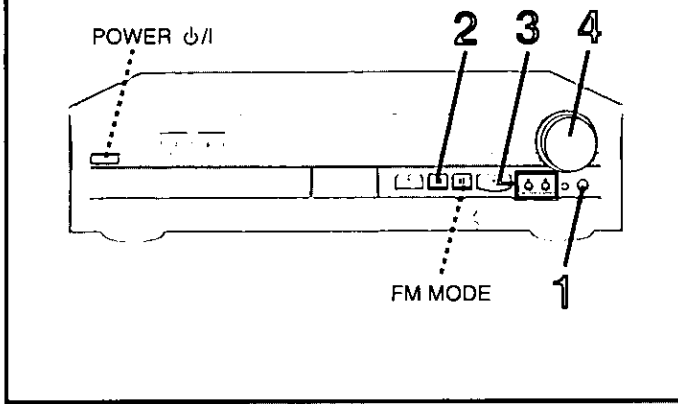

Preparation

- Press [POWER ϕ /I] to turn the unit on.

1 Press [SELECTOR] to select "FM" or "AM".

Each time the button is pressed;
DVD/CD \rightarrow FM \rightarrow AM \rightarrow TV \rightarrow VCR \rightarrow AUX

2 Press [TUNE MODE] to select "MANUAL".

Each time the button is pressed; MANUAL \leftrightarrow PRESET

3 Press [TUNING (\vee or \wedge)] to select the frequency of the required station.

"TUNED" is displayed when a radio station is tuned.
"STEREO" is displayed when a stereo FM broadcast is being received.

4 Adjust the volume.

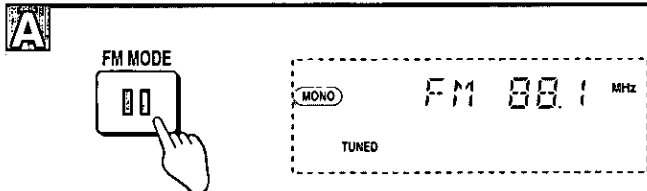
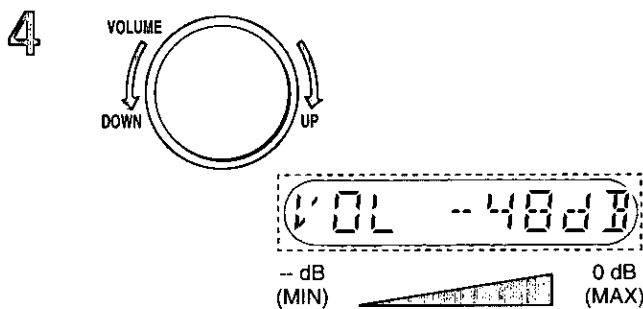
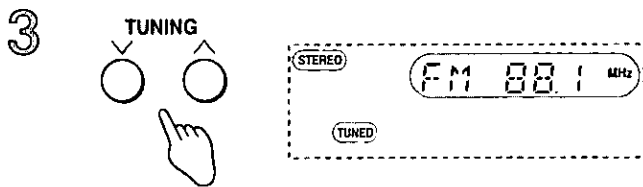

Auto tuning

Press and hold [TUNING (\wedge or \vee)] for a moment until the frequency starts changing rapidly. The unit begins auto tuning, stopping when it finds a station.

Note

Tuning may stop before a station is found if interference is encountered.

If noise is excessive in FM

Press [FM MODE] to display "MONO".

- This mode improves sound quality if reception is weak for some reason, but broadcasts are heard in monaural.
- Turn "MONO" off for normal listening. (Press [FM MODE] again.)

Allocation settings

Each country allocates broadcast bands according to their particular system.

For Latin America:

You can change the AM step. This unit can receive AM broadcasts allocated in 10- or 9-kHz steps.

For the U.S.A., Canada and others:

You can change the FM step. This unit can receive FM broadcasts allocated in 0.1- or 0.2-MHz steps.

Any frequencies that have been preset will be changed by this procedure. Be sure to carry out presetting again.

Press [SELECTOR] to select "FM". Now press and hold [SELECTOR]. After 5 seconds the display changes to show the current lowest frequency. Continue to hold down the button. After about 5 seconds, the minimum frequency changes and the step is changed at the same time.

Repeat this procedure to change the step back.

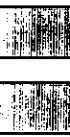

The radio: preset tuning

- Tuning is simpler if you preset stations.
 - You can preset 12 FM and 12 AM stations.
- Choose either automatic tuning, which presets all the stations the tuner can receive, or manual presetting, which allows you to select the stations to preset and the order they are to be preset in.

A Automatic presetting

Do the following once each for FM and AM.

Preparation

Tune to the frequency where presetting is to begin (⇒ page 29).

Press and hold [MEMORY].

Release the button when the frequency begins to change. The stations are preset into the channels in ascending order. The last station to be preset is played when presetting is complete.

Manual presetting

Preset the stations one at a time.

- 1 Press [MEMORY].
- 2 Tune to the required frequency.
- 3 Press [MEMORY].
- 4 Press [TUNING (∨ or ^)] to select a channel.
- 5 Press [MEMORY].

The station occupying a channel is erased if another station is preset in that channel.

B Selecting channels

- 1 Press [SELECTOR] to select "FM" or "AM".

Each time you press the button;

DVD/CD → FM → AM → TV → VCR → AUX

- 2 Press [TUNE MODE] to select "PRESET".

Each time the button is pressed; MANUAL ↔ PRESET

- 3 Press [TUNING (∨ or ^)] to select preset channel.

On the remote control

- 1 Press [TUNER/BAND] to select "FM" or "AM".
 - 2 Press the numbered buttons to select the channel.
 - For channels 10, 11, and 12, press [≥10/ENTER] then the two digits.
 - 10 ch: [≥10/ENTER] → [1] → [0]
 - 11 ch: [≥10/ENTER] → [1] → [1]
- Or
Press [CHANNEL (∧ or ∨)] to select a channel.

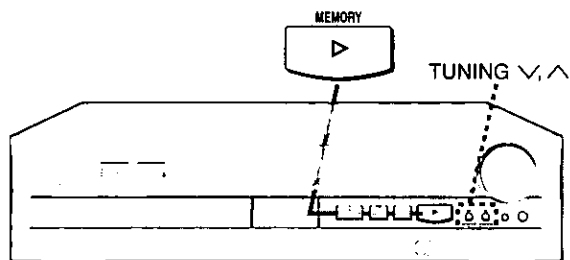

A

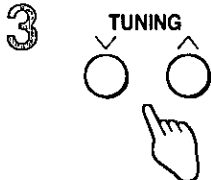
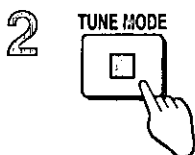
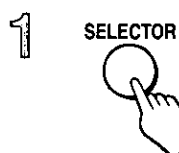
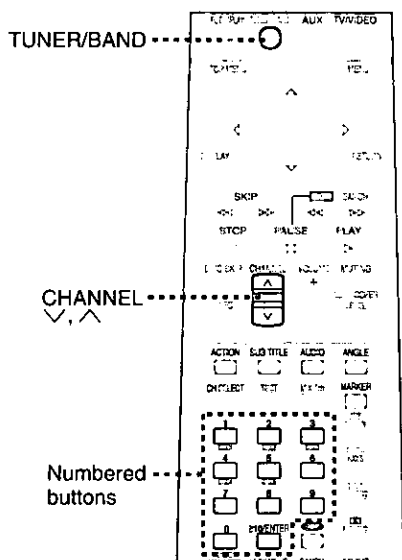
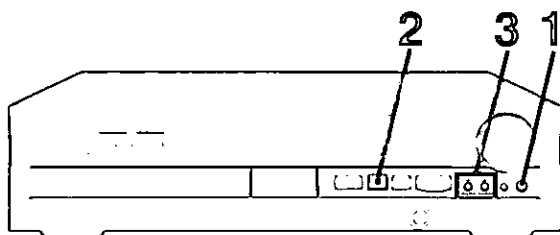

B



Sound field systems and effects you can enjoy with this unit

Sound field system	Features	Software	Other effects
<p>Dolby Digital (⇒ page 32)</p>	<p>Dolby Digital is a discrete 5.1 channel surround system developed for cinema use.</p> <p>This unit automatically recognizes DVDs that have been recorded with Dolby Digital.</p> <p>Not all Dolby Digital sources are recorded with 5.1 channels. Some sources marked Dolby Digital may be recorded in Dolby Surround, a 2 channel system.</p>	<p> DOLBY DIGITAL</p> <p>Software encoded with Dolby Digital can be identified with this mark.</p> <ul style="list-style-type: none"> • DVD 	<p>(A) Seat position (B) Center focus</p>
<p>Dolby Pro Logic (⇒ page 32)</p>	<p>Dolby Pro Logic is a decoding system that was developed to get a better sense of presence from sources encoded with Dolby Surround. The feeling of position has been improved by the addition of a separate center speaker channel.</p>	<p> DOLBY SURROUND</p> <p>Software encoded with Dolby Surround can be identified with this mark.</p> <ul style="list-style-type: none"> • DVD • Video tape • CD • Video CD 	<p>(A) Seat position (B) Center focus</p>
<p>SUPER SURROUND (⇒ page 34)</p>	<p>MOVIE This mode adds surround effects to movie software that hasn't been recorded with the above systems.</p> <p>MUSIC This mode adds surround effects to stereo sources.</p>	<p>Any stereo sound source except for the radio.</p>	<p>(A) Seat position —</p>
<p>SFC (Sound Field Control) (⇒ page 36)</p>	<p>Use SFC effects to change the sound quality and add reverberation.</p>	<p>Any source.</p>	<p>—</p>

Radio operations, Sound quality/sound field operations

(A) Seat position (⇒ page 35)

- This mode helps maintain the sound position even if the listening position itself is changed.

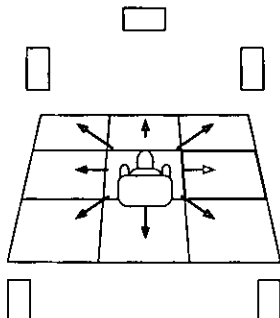

(B) Center focus (⇒ page 35)

- This mode makes it seem like the sound from the center speaker is coming from within the television. You can select one of two levels.
- The center speaker should be placed above the television.

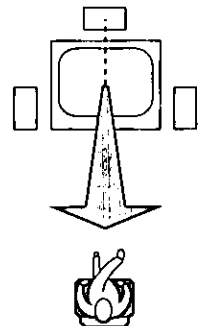

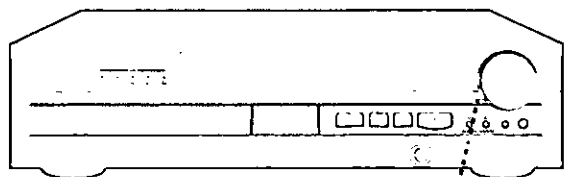

DD DIGITAL

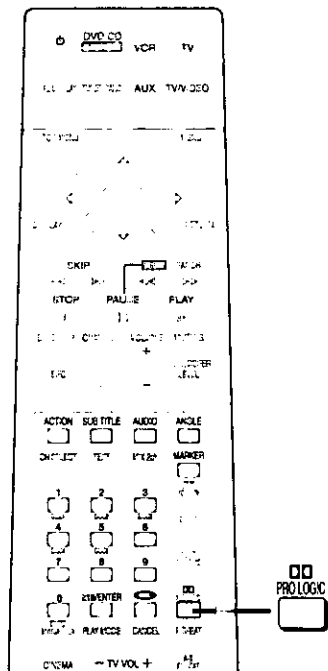

DD PRO LOGIC

A Enjoying sound with Dolby Digital



Playback the source (DVD).

Enjoy a powerful home-theater experience. "DD DIGITAL" and **DD** DIGITAL indicator light when Dolby Digital signals are detected.

Note

- If the disc contains multiple audio formats (Dolby Digital and DTS, for example) select the soundtrack recorded with Dolby Digital (= page 21).
- You can adjust the output level of the speakers if necessary (= page 33).

B Enjoying sound with Dolby Pro Logic Remote control only

(When playing DVD, videotapes, and CDs recorded with Dolby Surround)
Enjoy life-like surround effects.

Press [DD** PRO LOGIC].**

To turn off Dolby Pro Logic
Press [**DD** PRO LOGIC].

Note

- You can adjust the output level of the speakers if necessary (= page 33).

Note

Dolby Digital only works with DVD recorded with Dolby Digital. Dolby Pro Logic cannot be used if the source is radio or if headphones are connected.

A

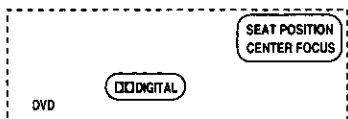

B



Sound field

[Remote control only]

Speaker level adjustments

If the level of the speakers appears to be different while listening to a source, sit where you would normally and perform the following to adjust the level of all the speakers to the same apparent level.

Preparations

To adjust Dolby Digital

Press [DVD/CD].

Turn other sound field systems off.

To adjust Dolby Pro Logic

Press [PRO LOGIC].

Select any source other than the radio.

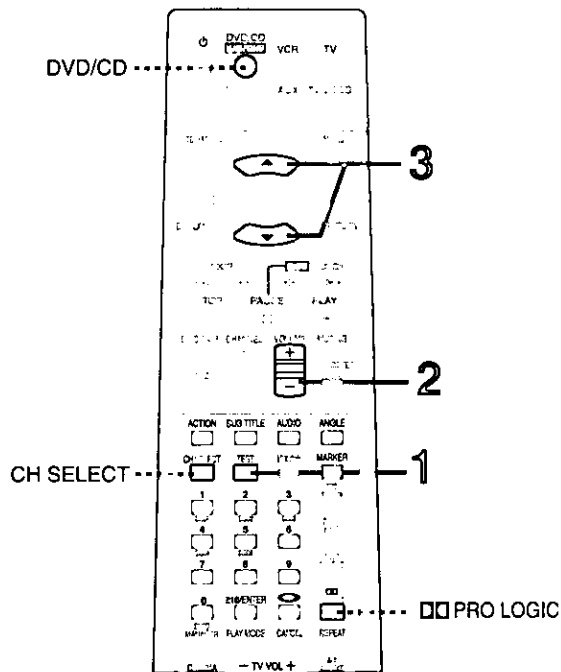

1 Press [TEST] to output a test signal.

The test signal is output in the following order.

Dolby Digital

L: Front speaker (left)

C: Center speaker

R: Front speaker (right)

RS: Surround speaker (right)

LS: Surround speaker (left)

※ No signal is output for the subwoofer.

Dolby Pro Logic

L: Front speaker (left)

C: Center speaker

R: Front speaker (right)

S: Surround speaker

※ No signal is output for the subwoofer.

2 Press [VOLUME (+ or -)] to set the volume level normally used for enjoying the source.

3 Press [Δ] or [∇] to adjust the level of each speaker to the same apparent level.

To stop the test signal

Press [TEST].

To adjust speaker level during play

1. Press [CH SELECT] to select the speaker channel.

In Dolby Digital

L → C → R → RS → LS

In Dolby Pro Logic

L → C → R → S

2. Press [Δ] or [∇].

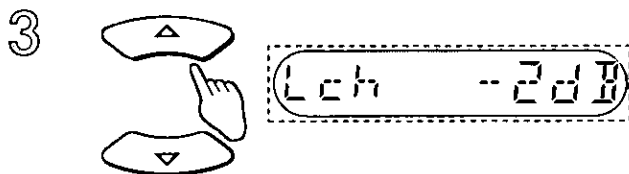
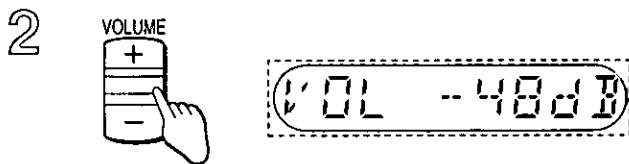
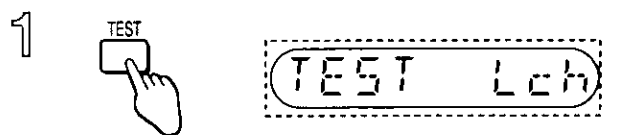

Sound field

A Using the seat position function (SEAT POSITION) Remote control only

Using this function makes you feel like you are sitting in the ideal seating position (in the center of the circle formed by the speakers), even if you cannot due to the layout of your room.

- 1 Press [SEAT POSITION].
- 2 While "▷" is flashing
Press the cursor buttons to select a position.

To cancel seat position

Press [SEAT POSITION] to clear "▷".

B Using the center focus effect (CENTER FOCUS) Remote control only

You can make the sound of the center speaker seem like it is coming from within the television. Place the center speaker above the television.

Press [CENTER FOCUS].

Each time you press the button;

CENTER FOCUS 1 → CENTER FOCUS 2 → Original display

The CENTER FOCUS 2 enhances the effect and makes it easier to hear dialogue even at low volume.

To cancel center focus

Press [CENTER FOCUS] to clear "▷".

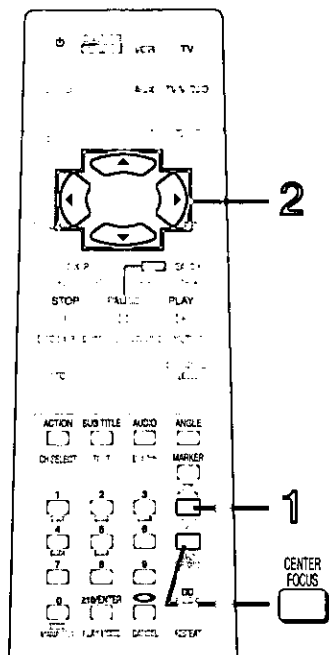

A

1

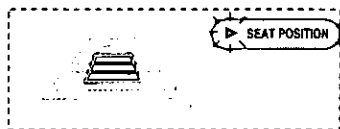

2

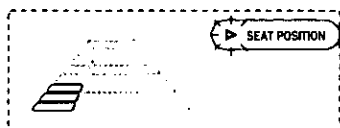
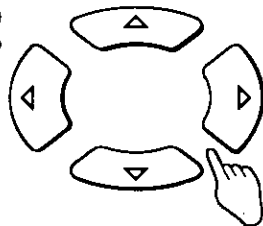

B

CENTER FOCUS

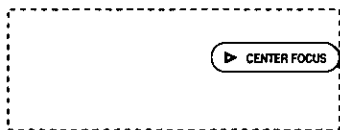

Sound field

Sound Field Control effects (SFC)

Remote control only

SFC can be used with any source.
There are seven SFC modes.

HEAVY: Adds punch to rock.

CLEAR: Clarifies higher sounds.

SOFT: Use this setting for background music.

DISCO: Produces lengthy reverberations like a disco.

LIVE: Adds gloss to vocals.

HALL: Expands the sound to make you feel like you were in a hall.

FLAT: No effect is added.

The factory setting is HEAVY.

Press [SFC].

To cancel SFC

Press [SFC] to select "FLAT".

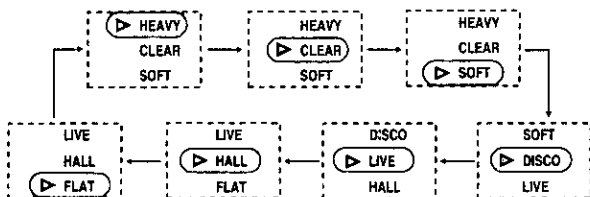
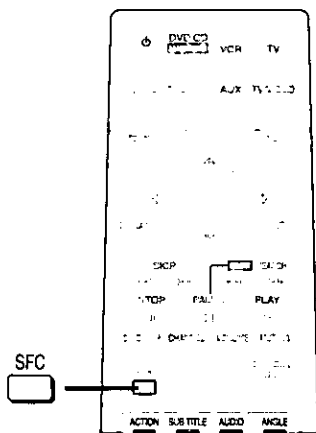

Timer function

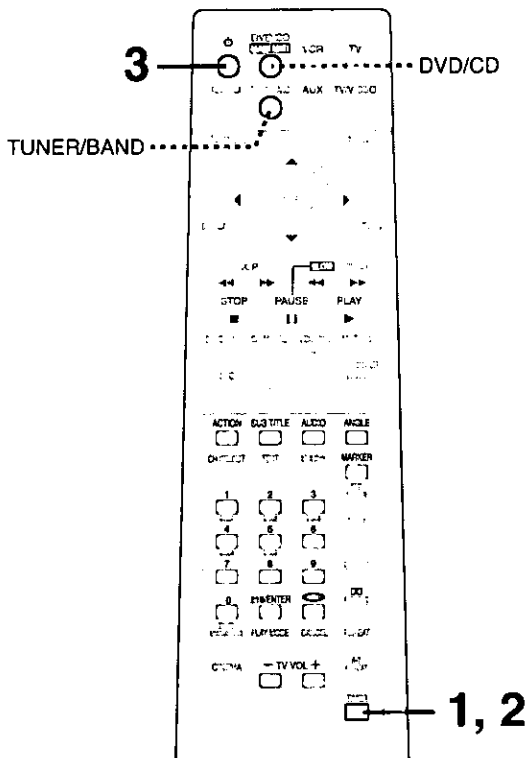
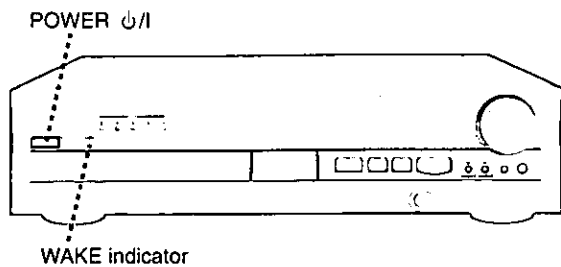

Remote control only

There are two timer functions: the sleep timer and the wake timer. They cannot be used together.

- **Sleep timer:**
The unit can be set to turn off after 30, 60, or 90 minutes. The timer is canceled if the unit is turned off.
- **Wake timer:**
The unit can be set to turn on and start playing the radio or an Audio CD, 5, 7, or 9 hours after you turn it off. The timer is canceled if the unit is turned on again.

Preparation

- Press [POWER \odot/I] to turn the unit on.
- Select the desired source.

Disc

Press [DVD/CD] to display "DVD/CD", and insert an Audio CD, etc.

The radio

Press [TUNER/BAND] to select "FM" or "AM" and tune in the desired station.

1 Press [TIMER] to select the desired timer mode.

The timer mode changes as follows:

SLEEP \leftrightarrow WAKE \leftrightarrow OFF

2 Press and hold [TIMER] to select the required time.

The display changes as follows:

- In sleep timer mode:

30 \rightarrow 60 \rightarrow 90 (minutes)

- In wake timer mode:

5H \rightarrow 7H \rightarrow 9H (hours)

3 **Wake timer mode only**

Press [\odot/I] to turn off the unit.

Main unit: Press [POWER \odot/I].

The "WAKE" indicator lights up.

Checking the remaining time on the sleep timer and the time set for the wake timer

Press [TIMER].

To cancel the timer

Press [TIMER] until "OFF" is displayed.

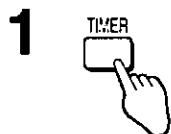

Sleep timer mode

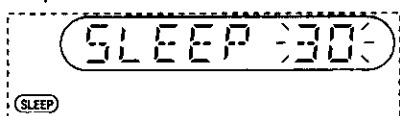

Wake timer mode

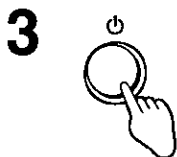
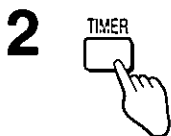
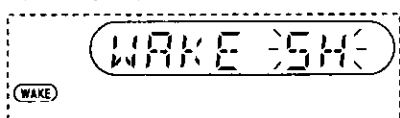

Convenient functions

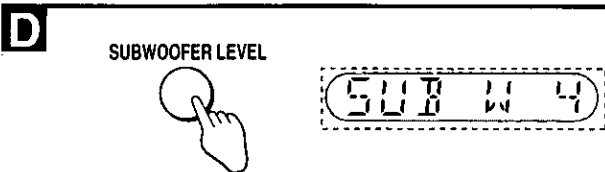
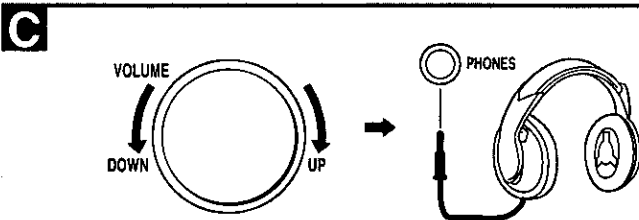
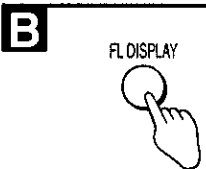
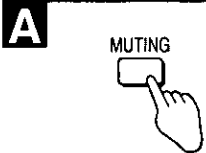
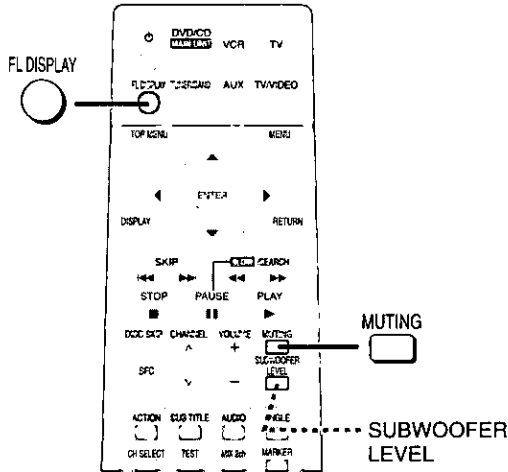
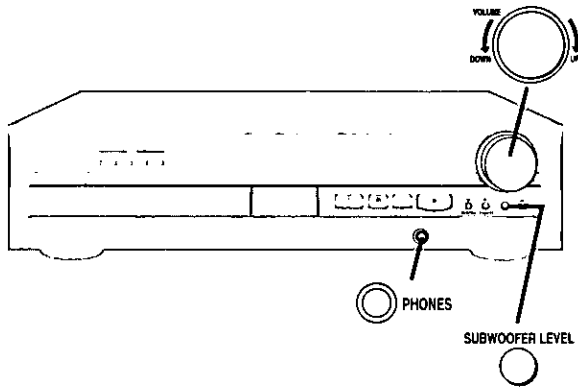

A To mute the volume Remote control only

Press [MUTING].

"MUTING" flashes on the display.

To cancel muting

Press [MUTING] or reduce the volume to minimum and raise it again.

Note

When the system is turned off, the muting operation will be automatically canceled.

B To turn off the unit's display Remote control only

Turning off the display can improve video viewing in a dark or dimly lit room.

Press [FL DISPLAY].

To turn on again

Press [FL DISPLAY].

C To listen through headphones

① Reduce the volume.

② Connect the headphones to the PHONES jack and adjust the volume.

Audio is automatically switched to stereo (2 channel).

If sound is distorted, turn on dynamic range compression (⇒ Audio—D. Range Compression, page 44).

Headphones

Plug type: 6.3 mm (1/4") stereo

Note

Avoid listening for prolonged periods of time to prevent hearing damage.

D Adjusting the bass

Press [SUBWOOFER LEVEL].

Remote control: Press [SUBWOOFER LEVEL].

Each time you press the button;

0 → 1 → 2 → 3 → 4

The factory setting is "4".

Sound is not heard from the subwoofer if you select "0".

Using other equipment

Connecting other equipment

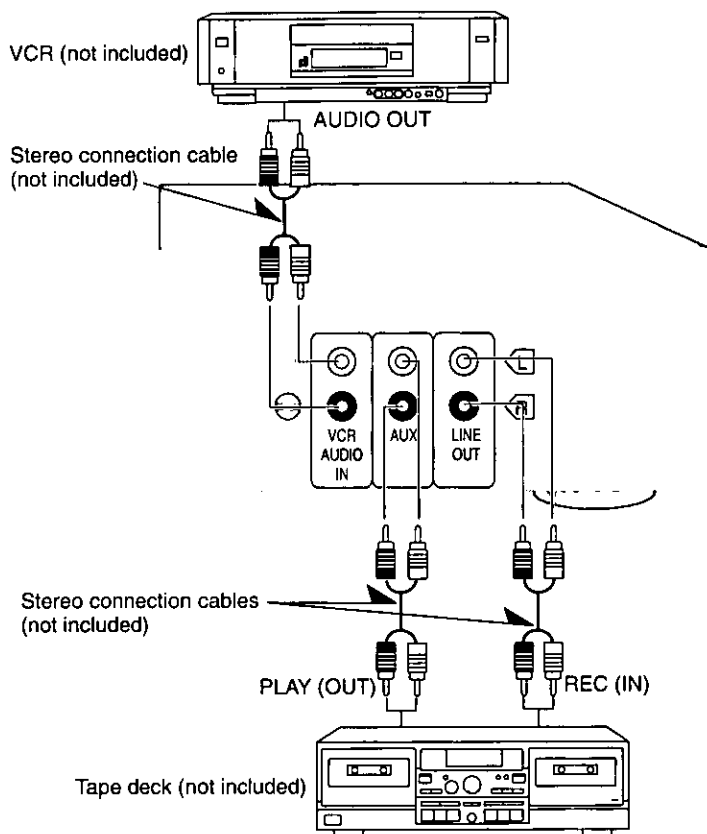

These are examples of connection. You can connect other recording equipment instead of a cassette deck. A record player, laser disc player, etc. can be connected to the AUX terminals.

To connect a record player

Connect the record player to a phono equalizer to amplify the signal, then connect the phono equalizer to the AUX terminals.

The volume will be very low if it is connected directly.

Outdoor antenna connections

Use outdoor antennas if radio reception is poor.

FM outdoor antenna (Using a television antenna)

Disconnect the FM indoor antenna.

An outdoor antenna should be installed by a qualified technician only.

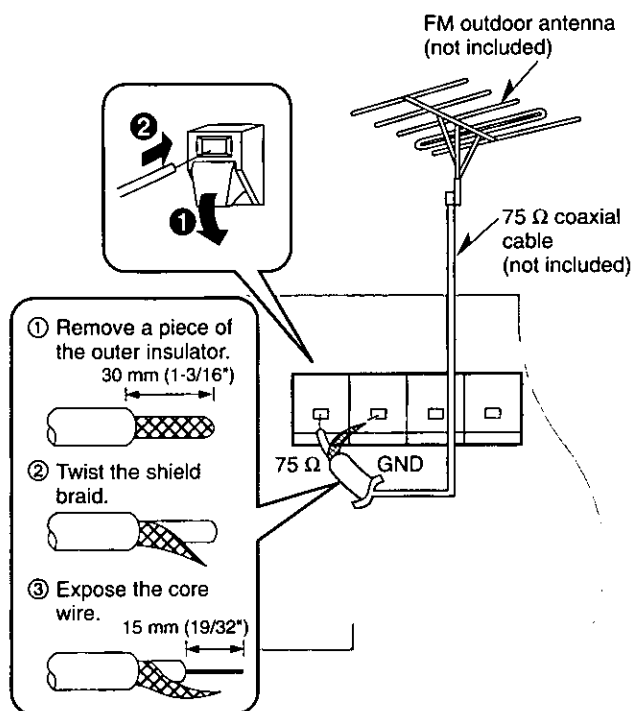

AM outdoor antenna (Using a vinyl wire)

Run a piece of vinyl wire horizontally across a window or other convenient location.

Leave the loop antenna connected.

When the unit is not in use, disconnect the outdoor antenna to prevent possible damage that may be caused by lightning. Never use an outdoor antenna during an electrical storm.

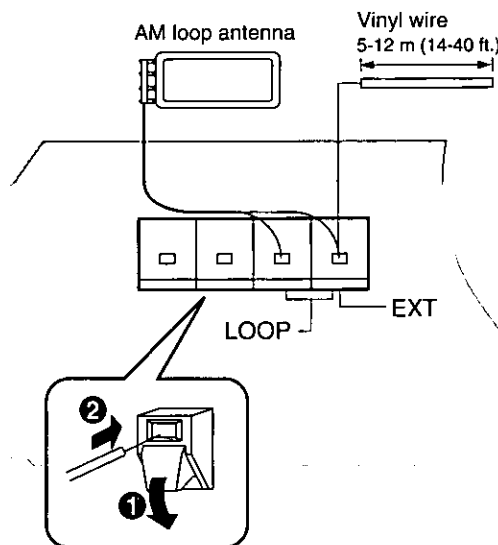

Other functions

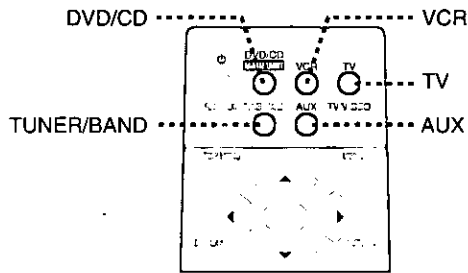
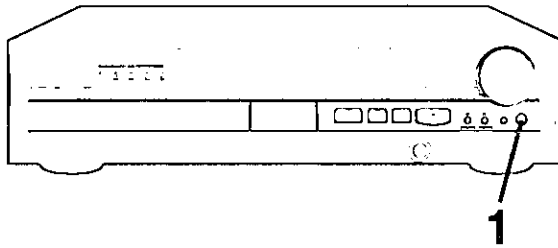

A

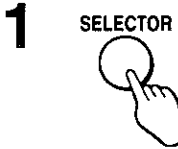

B

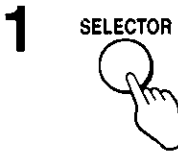

A Listening to an external source

1 Press [SELECTOR] to select "TV", "VCR" or "AUX".

Each time you press the button;

DVD/CD → FM → AM → TV → VCR → AUX

Remote control: Press [TV], [VCR] or [AUX].

2 Start the source.

B Recording to other equipment

Preparation

Connect and prepare the recording equipment (⇒ page 39).

1 Press [SELECTOR] to select "DVD/CD", "FM" or "AM".

Each time you press the button;

DVD/CD → FM → AM → TV → VCR → AUX

Remote control: Press [DVD/CD] or [TUNER/BAND].

2 Begin recording and start the source.

Using the remote control with other equipment

A Operating a television

Switching to TV operation mode

Press [TV].
The button lights.
The main unit also switches to TV.

Turning the TV on

Press [⏻].

Changing channels

Press [CHANNEL (▲ or ▼)].
You can also use the numbered buttons to select the channel.
For channels 10 or over, press [≥10/ENTER] then the two digits.
10 ch: [≥10/ENTER] → [1] → [0]
11 ch: [≥10/ENTER] → [1] → [1]

Adjusting the volume

Press [TV VOL (- or +)].

Switching the television's video input mode

Press [TV/VIDEO].

B Operating a video deck

Switching to VCR operation mode

Press [VCR].
The button lights.
The main unit also switches to VCR.

Turning the video deck on

Press [⏻].

Changing channels

Press [CHANNEL (▲ or ▼)].
Channels 1 to 10 can also be selected with the numbered buttons.
[0] selects channel 10.

Starting play

Press [PLAY ▶].

Fast-forwarding and rewinding

Press [SLOW/SEARCH (◀◀ or ▶▶)].

To stop play

Press [STOP ■].

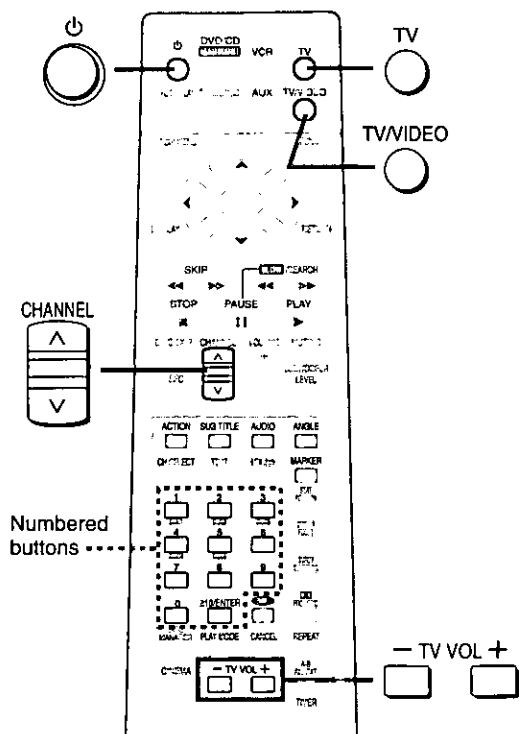
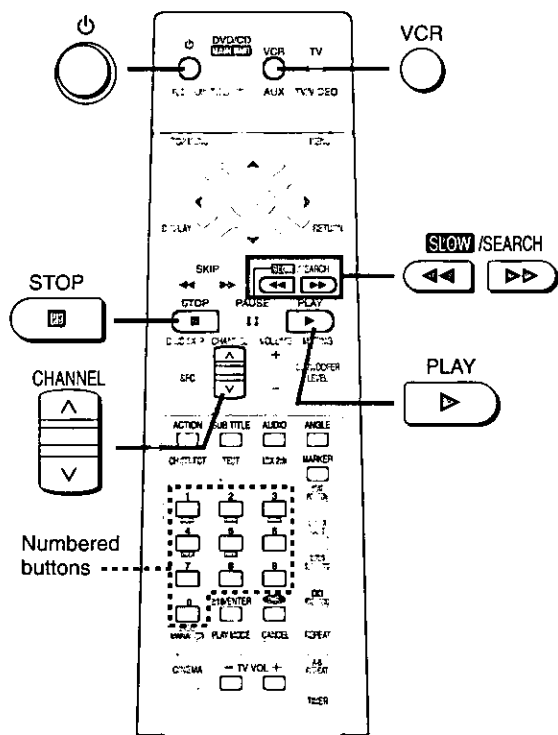
A**B**

Changing the remote control code

Change the remote control code in either of the following circumstances:

- If the Panasonic TV or VCR does not operate as a result of a difference in the remote control code.
- If you wish to operate some other make of TV or VCR.

Note

Even after changing the code there may be cases where certain operations cannot be done or operation is not possible at all.

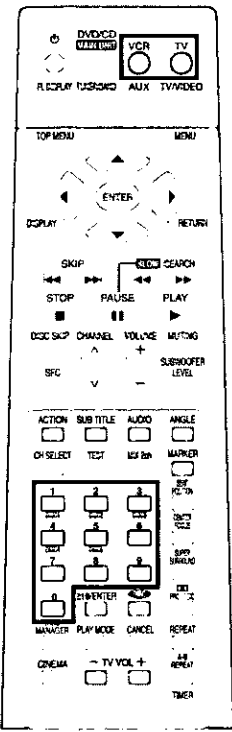

How to change the remote control code

VCR TV



Hold down the button corresponding to the component you wish to operate.

Continue to hold the button down and...



1 2 3



Aim the remote control at the component you wish to operate and carefully and slowly press the numbered buttons to enter the appropriate two-digit code number.

(Refer to the table below for the code number.)

4 5 6



When the two-digit code number is entered, the remote control will automatically output the on/off signal.

7 8 9



If the remote control has been correctly changed to the code for the component to be operated, the component will be switched ON or OFF.

0



Note

If there is more than one code number indicated in the code table, repeat the above procedure until you find a code number for which the power of the component is switched ON or OFF.

TV				VCR			
Manufacturer	Code No.	Manufacturer	Code No.	Manufacturer	Code No.	Manufacturer	Code No.
Panasonic	01, 02, 26	RCA	03, 07, 09, 13, 23, 24, 25	Panasonic	01, 02, 09, 33	Philips	02, 09, 12
Sony	04	Sanyo	14	Sony	05, 06, 07, 35, 36, 37	Pioneer	09
Fisher	14	Sharp	08, 21	Fisher	13, 14, 15, 18, 34	Quasar	01, 02, 09, 33
G-E	02, 03, 07, 09	Sylvania	06, 07, 15	Funai	08, 30	RCA	02, 03, 04, 09, 10, 11, 12, 23, 24, 26
Gold Star	07, 15	Symphonic	17	G-E	02, 03, 11	Sanyo	14, 18, 34
Hitachi	05, 07	Toshiba	10, 21	Gold Star	27	Sharp	16, 17
JVC	12	Zenith	18, 20	Hitachi	09, 10, 11	Shintom	32
LXI	03, 06, 07, 10, 14, 15			JVC	19, 25, 31, 38, 39, 40	Sylvania	02, 09, 12, 30
Magnavox	06, 07, 11, 15, 22			LXI	10, 13, 14, 15, 18, 27, 30	Symphonic	30
Mitsubishi	07, 15, 16, 21					Toshiba	23, 24
Mitsubishi	07, 15					Zenith	20
Philco	06, 07			Magnavox	02, 09, 12		
Philips	06			Mitsubishi	21, 22, 28, 29		
Pioneer	02, 10, 19			NEC	19, 25, 31, 38		
Quasar	02			Philco	02, 09, 12, 30		

Note

- To prevent accidental operation, press [DVD/CD] after operation so the unit is ready to operate this unit.

Initial settings

Change the initial settings to suit your preferences and to suit the unit to the environment in which it is being used. These settings are retained in memory until they are changed, even if the unit is turned off.

Changing the initial settings

Remote control only

See pages 44–45 for menu and option details.

Preparation

Press [DVD/CD] to select "DVD/CD". The unit automatically comes on.

- 1 Press [ACTION].
The screen shows the disc menu (a) first.
- 2 Press [◀] or [▶] to select the menu's tab.
The screen changes to display the menu.
 - Disc menu (a)
 - Video menu (b)
 - Audio menu (c)
 - Display menu (d)
- 3 Press [▲] or [▼] to select the item you want to change and press [ENTER].
- 4 Press [▲] or [▼] to select the option and press [ENTER].
The screen now shows the menu again.

To return to the previous screen

Press [RETURN].

To exit the initial settings menu

Press [ACTION].

Note

- The initial settings cannot be accessed while program mode (▶ page 25) or random mode (▶ page 23) is on. Press [PLAY MODE] to turn the mode off.
- The initial settings cannot be accessed while disc manager (▶ page 24) is on. Press [DISC MANAGER] to turn the mode off.

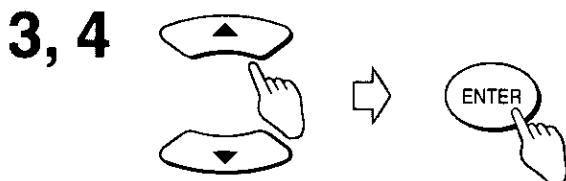
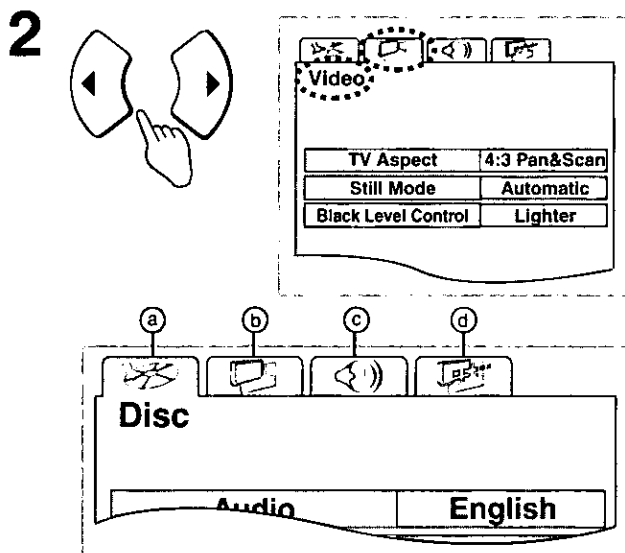
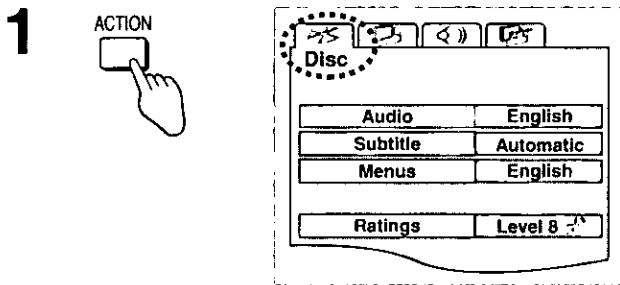
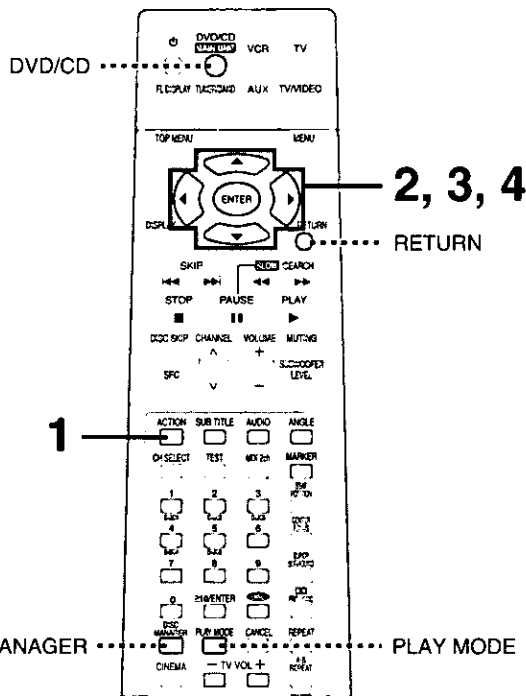

Summary of initial settings

This chart shows the initial settings for this unit.
See page 43 for details on operation.
Shaded items are the factory settings.

The menu and on-screen message language has been factory pre-set to English. You can change the language by going to "Menu Language" in the Display menu.

Main menu	Menu	Options
Disc DVD	Audio Choose the preferred audio language.	English Original French Other **** Spanish
	Subtitle Choose the preferred subtitle language.	Automatic Spanish English Other **** French
	Menus Choose the preferred language for disc menus.	English Other **** French Spanish
	Ratings Set a ratings level to limit DVD play.	Setting ratings (When level 8 is selected) 8 No Limit 1 to 7 0 Lock All Changing ratings (When level 0–7 is selected) Unlock Player Change Level Change Password Temporary Unlock
Video DVD VCD	TV Aspect Choose the setting to suit your television and preference (⇒ page 13).	4:3 Pan & Scan 4:3 Letterbox 16:9
	Still Mode Specify the type of picture shown when paused.	Automatic Field Frame
	Black Level Control Change the black level of the picture.	Lighter Darker
Audio	Speaker Setting DVD (Dolby Digital only) Set the delay time for your center and surround speakers (⇒ page 46).	Center: 0/1.3/2.6/3.9/5.3 ms Surround (L/R): 0/5.3/10.6/15.9 ms
	D.Range Compression DVD (Dolby Digital only) Change the dynamic range. Dynamic range is the difference between the loudest sound and the softest sound.	Off On
	Audio during Search DVD VCD Choose whether to have sound during search.	On Off
Display	Menu Language Choose the preferred language for these menus and the on-screen messages.	English Français Español
	On-Screen Messages Choose whether to show on-screen messages or not.	On Off

Changes to the initial settings remain intact after the unit is turned off.
Do the setting procedures again to restore to the original settings.

	Remarks
<p>"Other ****": Input a code number with the numbered buttons (⇒ page 46).</p> <p>"Original": The original language of each disc will be selected.</p> <p>"Automatic": If the language selected for "Audio" is not available, subtitles of that language will automatically appear if available on that disc.</p>	<p>Some discs are designed to start in a certain language despite any changes you make here.</p>
<p>Level 8: All DVDs can be played.</p> <p>Level 1 to 7: Prohibits play of DVDs with corresponding ratings recorded on them.</p> <p>Level 0: Prohibits play of all DVDs.</p>	<ul style="list-style-type: none"> • The password screen is shown if you choose levels 0 to 7. • Select "Level 0" to prevent play of discs that do not have ratings levels recorded on them.
	<p>The password screen is shown when you select "Ratings" if levels 0 to 7 have been selected.</p>
<p>Field: Less blurred field stills are shown. Select if jittering occurs when "Automatic" is selected.</p> <p>Frame: Sharper frame stills are shown. Select if small text or fine patterns cannot be seen clearly when "Automatic" is selected.</p>	
<p>When the center/surround speakers cannot be located in the ideal position.</p>	
	<p>Turn dynamic range compression on in the following cases.</p> <ul style="list-style-type: none"> • For clear dialogue when listening at low volume. • When sound is distorted while playing multi-channel DVD through two channels (when headphones are connected or when using the MIX 2CH mode).

Language code list

6565: Afar	7079: Faroese	7678: Lingala	8375: Slovak
6566: Abkhazian	7082: French	7679: Laotian	8376: Slovenian
6570: Afrikaans	7089: Frisian	7684: Lithuanian	8377: Samoan
6577: Ameharic	7165: Irish	7686: Latvian, Lettish	8378: Shona
6582: Arabic	7168: Scots Gaelic	7771: Malagasy	8379: Somali
6583: Assamese	7176: Galician	7773: Maori	8381: Albanian
6588: Aymara	7178: Guarani	7775: Macedonian	8382: Serbian
6590: Azerbaijani	7185: Gujarati	7776: Malayalam	8385: Sundanese
6665: Bashkir	7265: Hausa	7778: Mongolian	8386: Swedish
6669: Byelorussian	7273: Hindi	7779: Moldavian	8387: Swahili
6671: Bulgarian	7282: Croatian	7782: Marathi	8465: Tamil
6672: Bihari	7285: Hungarian	7783: Malay	8469: Telugu
6678: Bengal; Bangla	7289: Armenian	7784: Maltese	8471: Tajik
6679: Tibetan	7365: Interlingua	7789: Burmese	8472: Thai
6682: Breton	7378: Indonesian	7865: Nauru	8473: Tigrinya
6765: Catalan	7383: Icelandic	7869: Nepali	8475: Turkmen
6779: Corsican	7384: Italian	7876: Dutch	8476: Tagalog
6783: Czech	7387: Hebrew	7879: Norwegian	8479: Tonga
6789: Welsh	7465: Japanese	7982: Oriya	8482: Turkish
6865: Danish	7473: Yiddish	8065: Panjabi	8484: Tatar
6869: German	7487: Javanese	8076: Polish	8487: Twi
6890: Bhutani	7565: Georgian	8083: Pashto, Pushto	8575: Ukrainian
6976: Greek	7575: Kazakh	8084: Portuguese	8582: Urdu
6978: English	7576: Greenlandic	8185: Quechua	8590: Uzbek
6979: Esperanto	7577: Cambodian	8277: Rhaeto-Romance	8673: Vietnamese
6983: Spanish	7578: Kannada	8279: Romanian	8679: Volapük
6984: Estonian	7579: Korean	8285: Russian	8779: Wolof
6985: Basque	7583: Kashmiri	8365: Sanskrit	8872: Xhosa
7065: Persian	7585: Kurdish	8368: Sindhi	8979: Yoruba
7073: Finnish	7589: Kirghiz	8372: Serbo-Croatian	9072: Chinese
7074: Fiji	7665: Latin	8373: Singhalese	9085: Zulu

Calculating delay time

The sound from speakers can reach the listening position at different times depending on placement. You can allow for this difference by changing the delay time of the center and surround speakers.

Center speaker delay time

If $D_1 \leq D_2$, then set delay time to 0 ms.

If $D_1 > D_2$, then set delay time as follows.

Difference between D_1 and D_2	Delay time
50 cm	1.3 ms
100 cm	2.6 ms
150 cm	3.9 ms
200 cm	5.3 ms

Surround speaker delay time

If $D_1 \leq D_3$, then set delay time to 0 ms.

If $D_1 > D_3$, then set delay time as follows.



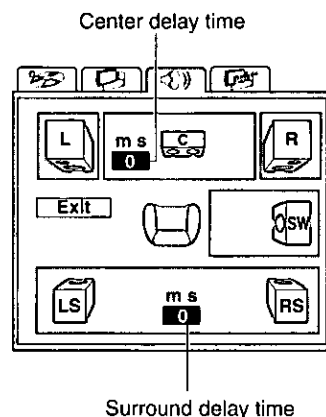
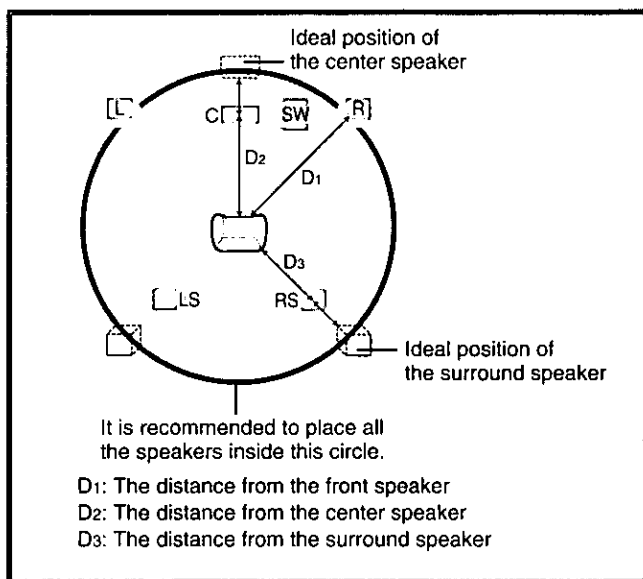









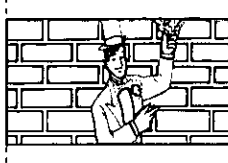



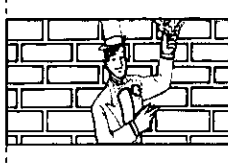

Difference between D_1 and D_3	Delay time
200 cm	5.3 ms
400 cm	10.6 ms
600 cm	15.9 ms



How different kinds of software appear on your television

DVD software is recorded in a variety of picture formats, and how they appear on your TV depends on the software, the kind of TV you have, and the picture mode your TV is set to.

- Letterbox refers to pictures where black bands appear at the top and bottom.
- Pan & scan refers to pictures where part of the picture is cut off so it fills the whole screen.

Television and picture mode Software format	4:3	16:9 full mode	16:9 zoom mode	16:9 auto mode
Wide screen, pan and scan 	Edges cut off 	Full screen 	Top and bottom cut off 	Full screen 
Wide screen, non-pan and scan 	Letterbox 			
Regular (4:3) 	Full screen 	Screen stretched horizontally 	Top and bottom cut off 	Full screen with black bands on the left and right 
Regular (4:3) letterbox 	Letterbox 	Letterbox with screen stretched horizontally 	Full screen 	Letterbox with extremities of picture stretched 

The names given to the television picture modes depend on the maker of your television. There may also be slight differences in how the pictures appear on the screen. Refer to your television's operating instructions for details.

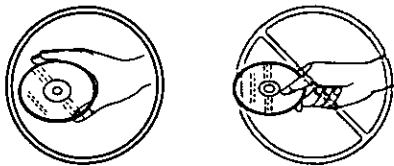
A

Play surface (shiny side)

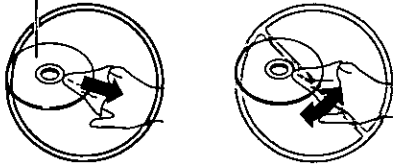

Wipe from inside outward.

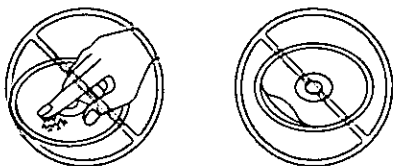
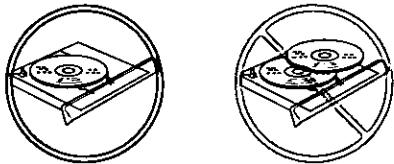
**B**

8 cm

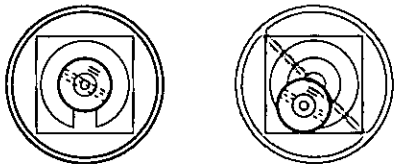

12 cm

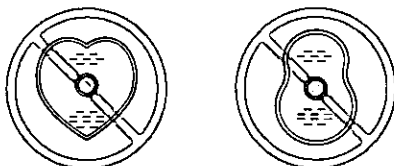
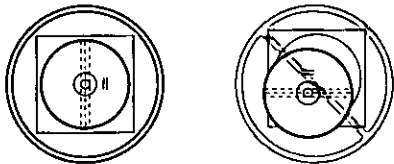
**Concerning discs**

With this system, you can only play discs having these marks. However, do not use irregular shaped discs. Discs of this sort can damage the unit.

**A Handling precautions**

- If you are taking the disc from a cold to a warm environment, moisture may form on the disc. Wipe with a soft, dry lintfree cloth before using the disc.
- Do not write on the label side with a ball-point or other writing instrument.
- Do not use record cleaning sprays, benzine, thinner, static electricity prevention liquids or any other solvent.
- Do not attach labels or stickers to discs. (Do not use discs with exposed adhesive from tape or left over peeled off stickers.)
- Do not use scratch-proof protectors or cover other than those specified for use with this system.
- Do not use discs printed with label printers available on the market.

Storage precautions

Be sure to store discs in their cases to protect them from dust, scratches, and warping.

Do not place or store discs in the following places.

- Locations exposed to direct sunlight
- Humid or dusty locations
- Locations directly exposed to a heat vent or heating appliance
- In the glove compartment or on the rear deck of an automobile

B To prevent damage

Always observe the following points.

- Load only 1 disc per tray.
- Load discs as shown in figure.
- An adaptor is not needed with 8 cm discs (singles).
- Set the system on a flat, level surface.
Do not set it on top of magazines, inclined surfaces, etc.
- Do not move the system while trays are opening/closing, or when loaded.
- Do not put anything except discs in trays.
- Do not use cleaning discs or discs which are badly warped or cracked.
- Do not use discs with poorly attached labels or stickers.
Adhesive protruding from underneath stickers or left over from peeled off stickers can cause your stereo to malfunction.
- Do not use irregular shaped discs.

Video

Frame

Frames are the still pictures that go together to make a moving picture. There are about thirty frames shown each second.



Field

One frame is made up of two fields. A regular television shows these fields one after the other to create frames.

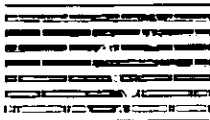

One field

Frame still and field still

A still is shown when you pause a moving picture. A frame still is made up of two alternating fields, so the picture may appear blurred, but overall quality is high. A field still is not blurred, but it has only half the information of a frame still so picture quality is lower.

I/P/B

MPEG 2, the video compression standard adapted for use with DVD, codes frames using these three picture types.

I: Intra coded picture (I-picture)

This is the standard picture and is a complete picture in itself. This means it has the best picture quality and is the best to use when adjusting the picture.

P: Predictive coded picture (P-picture)

This picture is calculated based on past I and P-pictures.

B: Bidirectionally-predictive coded picture (B-picture)

This picture is calculated by comparing past and future I and P-pictures so it has the lowest volume of information.

Digital audio

Decoder

A decoder restores the coded audio signals on DVDs to normal. This is called decoding.

Dolby Digital

This method of coding digital signals was developed by Dolby Laboratories. The signals are highly compressed, enabling a large amount of information to be recorded on one disc.

Sampling rate

This is the number of samples of sound taken per second during conversion to a digital signal. Sampling frequency is expressed in kilohertz (kHz). A high sampling frequency results in a sound close to the original when played back.

PCM (pulse code modulation), Linear PCM

PCM is the usual digital method used for music CDs. DVDs have a greater volume so they use linear PCM, which has a higher sampling rate.

Bitstream

This is the digital form of multiple channel audio data (e.g., 5.1 channel) before it is decoded into its various channels.

Other

Track

This is the smallest division on CD and video CD, and usually equates to a single song.

Chapter

This is the smallest division on DVD and is roughly equivalent to a track.

Title

This is the largest division on DVD.

Playback control (PBC)

This method of controlling disc play is included on version 2.0 video CDs. You are able to interact with the disc through menus.

Troubleshooting guide

Before requesting service, make the below checks. If you are in doubt about some of the check points, or if the remedies indicated in the chart do not solve the problem:

In the U.S.A., contact the Panasonic Customer Call Center at 1-800-211-7262, or e-mail consumerproducts@panasonic.com, or web site (<http://www.panasonic.com>).

In Canada, contact Panasonic Canada Inc. Customer Care Centre at 1-800-561-5505, or web site (www.panasonic.ca), or an authorized Servicentre nearest you.

Common problems		Reference pages
No power.	<ul style="list-style-type: none"> • Ensure the power cord is connected. 	10
No sound.	<ul style="list-style-type: none"> • Turn the volume up. • Turn muting off. • Check speaker connections. 	15, 29 38 8
Sounds are unfixed or left and right are reversed.	<ul style="list-style-type: none"> • Check speaker connections. 	8
Humming heard during play.	<ul style="list-style-type: none"> • A power cord or fluorescent light is near the cables. Keep other appliances and cords away from this unit's cables. • If possible in your area, turn the AC power supply cord's plug or connector over to reverse the plug's polarity. 	— —
Sound stops suddenly during play.	<ul style="list-style-type: none"> • The speaker cords may have shorted. Turn the unit off and reconnect the cords. 	8
The unit's display is off.	<ul style="list-style-type: none"> • Press [FL DISPLAY] on the remote control to turn the display on. 	38
"ERROR" is displayed.	<ul style="list-style-type: none"> • Incorrect operation performed. Read the instructions and try again. 	—
"F61" is displayed.	<ul style="list-style-type: none"> • The speaker cords may have shorted. Turn the unit off and reconnect the cords. If this does not fix the problem, consult your dealer. 	8
No sound from the subwoofer.	<ul style="list-style-type: none"> • Check that the subwoofer has not been set to "0". 	38

Radio		Reference pages
The radio cannot be tuned in or there is a lot of noise and interference.	<ul style="list-style-type: none"> • Adjust the position of the FM or AM antenna. • Turn off nearby televisions, video decks, and satellite receivers. • Separate the antenna from other cables and leads. • You may need an outdoor antenna. 	10 — — 39

Disc		Reference pages
<p>The display is wrong or play won't start.</p>	<ul style="list-style-type: none"> • The disc may be upside down. • Replace the disc if it is scratched, warped, or nonstandard. • Condensation may have formed in the player due to a sudden change in temperature. Wait about an hour for it to clear and try again. 	<p>14 48 —</p>
<p>Certain sections cannot be played.</p>	<ul style="list-style-type: none"> • Wipe the disc with a soft cloth if it is dirty. 	<p>48</p>
<p>Noise is output when a CD is played.</p>	<ul style="list-style-type: none"> • Check the disc. If it is a DTS CD, it cannot be played. 	<p>—</p>
<p>"DTS NO AUDIO" appears on the display.</p>	<ul style="list-style-type: none"> • This unit is unable to decode DTS signals. 	<p>—</p>
<p>"DTS CD" appears on the display.</p>	<ul style="list-style-type: none"> • This unit is unable to decode DTS signals. 	<p>—</p>
<p>"DVD U11" appears on the display.</p>	<ul style="list-style-type: none"> • The disc is dirty. Wipe it with a soft cloth. 	<p>48</p>
<p>"DVD H□□" appears on the display.</p>	<ul style="list-style-type: none"> • A problem has occurred. Turn the unit off and unplug the AC cord. Wait a moment and then plug the cord in and turn on the unit again. If the unit is still not working correctly, consult your dealer. 	<p>—</p>
<p>"TAKE OUT DISC" appears on the display.</p>	<ul style="list-style-type: none"> • A problem has occurred with the tray mechanism. The tray will open automatically. Take out the disc and close the tray. The unit will make the disc changing noises for a few moments and then should operate normally. 	<p>—</p>
<p>You have forgotten your ratings password.</p>	<ul style="list-style-type: none"> • Reset the unit to its original factory settings. Do the following to restore the unit to the condition it was in at the time of shipment. This clears the ratings settings. Press [■] on the main unit and [≥10/ENTER] on the remote control at the same time for about 3 seconds until the message "Initialized" disappears from the television screen. 	<p>—</p>
<p>Languages you selected in the initial settings menu are not used for the soundtrack and subtitles.</p>	<ul style="list-style-type: none"> • The selected languages are not recorded on the DVD or the DVD has been designed to automatically play a certain language. 	<p>—</p>

The remote control		Reference pages
<p>The remote control doesn't work.</p>	<ul style="list-style-type: none"> • Check the batteries are inserted correctly. • Aim the remote control at the main unit and remove obstacles between them. • Replace the batteries if they are worn out. • It may be in the TV or VCR operation mode. Press [DVD/CD] to operate this unit. • If the remote control doesn't operate the television or VCR, try changing the code. This remote control cannot operate some televisions or VCRs. 	<p>7 7 — 12 41, 42</p>

Maintenance

If the surfaces are dirty

To clean this unit, wipe with a soft, dry cloth.

If the surfaces are extremely dirty, use a soft cloth dipped in a soap-and-water solution or a weak detergent solution.

- Never use alcohol, paint thinner or benzine to clean this unit.
- Before using chemically treated cloth, read the instructions that came with the cloth carefully.

When moving the unit

- 1 Remove all discs.**
- 2 Press [POWER \odot/I] to turn the unit off.**
- 3 Disconnect the AC power cord.**

Product Service

Do not attempt to remove the cover(s) or repair the unit yourself. Refer servicing to qualified personnel only.

Product information

For product service, product information or assistance with product operation, refer to the servicenter directory.

Listening caution



Selecting fine audio equipment such as the unit you've just purchased is only the start of your musical enjoyment. Now it's time to consider how you can maximize the fun and excitement your equipment offers. This manufacturer and the Electronic Industries Association's Consumer Electronics Group want you to get the most out of your equipment by playing it at a safe level. One that lets the sound come through loud and clear without annoying blaring or distortion—and, most importantly, without affecting your sensitive hearing.

We recommend you to avoid prolonged exposure to excessive noise.

Sound can be deceiving. Over time your hearing "comfort level" adapts to higher volumes of sound. So what sounds "normal" can actually be loud and harmful to your hearing.

Guard against this by setting your equipment at a safe level BEFORE your hearing adapts.

To establish a safe level:

- Start your volume control at a low setting.
- Slowly increase the sound until you can hear it comfortably and clearly, and without distortion.

Once you have established a comfortable sound level:

- Set the dial and leave it there.

Taking a minute to do this now will help to prevent hearing damage or loss in the future. After all, we want you listening for a lifetime.

■ AMPLIFIER SECTION

(SC-HT70 for the U.S.A. and Canada)

FTC TTL POWER OUTPUT	240 W
120 Hz–20 kHz, 1.0 % total harmonic distortion	
FRONT	30 W per ch (6 Ω)
CENTER	30 W (6 Ω)
SURROUND	30 W per ch (6 Ω)
45 Hz–120 Hz, 1.0 % total harmonic distortion	
SUBWOOFER	90 W (6 Ω)
RMS TTL POWER OUTPUT	300 W
120 Hz–20 kHz, 10 % total harmonic distortion	
FRONT	36 W per ch (6 Ω)
CENTER	36 W (6 Ω)
SURROUND	36 W per ch (6 Ω)
45 Hz–120 Hz, 10 % total harmonic distortion	
SUBWOOFER	120 W (6 Ω)
Input sensitivity/input impedance	
AUX	250 mV, 10 kΩ

■ AMPLIFIER SECTION (SC-HT65 for the U.S.A.)

FTC TTL POWER OUTPUT	200 W
120 Hz–20 kHz, 1.0 % total harmonic distortion	
FRONT	25 W per ch (6 Ω)
CENTER	25 W (6 Ω)
SURROUND	25 W per ch (6 Ω)
45 Hz–120 Hz, 1.0 % total harmonic distortion	
SUBWOOFER	75 W (6 Ω)
RMS TTL POWER OUTPUT	250 W
120 Hz–20 kHz, 10 % total harmonic distortion	
FRONT	30 W per ch (6 Ω)
CENTER	30 W (6 Ω)
SURROUND	30 W per ch (6 Ω)
45 Hz–120 Hz, 10 % total harmonic distortion	
SUBWOOFER	100 W (6 Ω)
Input sensitivity/input impedance	
AUX	250 mV, 10 kΩ

■ AMPLIFIER SECTION (For Latin America and others)

RMS TTL POWER OUTPUT	300 W
(10 % total harmonic distortion)	
FRONT	1 kHz 36 W per ch (6 Ω)
CENTER	1 kHz 36 W (6 Ω)
SURROUND	1 kHz 36 W per ch (6 Ω)
SUBWOOFER	80 Hz 120 W (6 Ω)
PMPO TTL POWER OUTPUT	2200 W
DIN TTL POWER OUTPUT	220 W
(1 % total harmonic distortion)	
FRONT	1 kHz 26 W per ch (6 Ω)
CENTER	1 kHz 26 W (6 Ω)
SURROUND	1 kHz 26 W per ch (6 Ω)
SUBWOOFER	80 Hz 90 W (6 Ω)
Input sensitivity/input impedance	
AUX	250 mV, 10 kΩ

■ DISC SECTION

Disc	
DVD	8 cm/12 cm single-sided, single-layer 8 cm/12 cm single-sided, double-layer 8 cm/12 cm double-sided, double-layer (one layer per side)
CD/VCD	8 cm/12 cm (CD-R/RW)
Video	
Signal system	NTSC
Output level	Composite video 1 Vp-p (75 Ω)
S-video Y	1 Vp-p (75 Ω)
S-video C	0.286 Vp-p (75 Ω/NTSC)
Audio	
Sampling frequency	
CD	44.1 kHz
DVD	48 kHz/96 kHz
Decoding	16/20/24 bit linear
Wow and flutter	Below measurable limit
D/A converter	Delta-sigma DAC
Pick up	
Beam Source	Semiconductor Laser
Wavelength	
DVD	658 nm
VCD/CD	790 nm

■ FM TUNER SECTION

Frequency range	
(For Latin America)	87.50–108.00 MHz (50 kHz steps)
(For the U.S.A., Canada and others)	87.9–107.9 MHz (200 kHz steps) 87.5–108.0 MHz (100 kHz steps)
Sensitivity	16.3 dBf (1.8 μV, IHF)
Antenna terminals	75 Ω unbalanced

■ AM TUNER SECTION

Frequency range	
(For Latin America)	522–1629 kHz (9 kHz steps)
(For the U.S.A., Canada and others)	520–1630 kHz (10 kHz steps) 520–1710 kHz (10 kHz steps)
Sensitivity	
(For Latin America)	
S/N 20 dB at 999 kHz	500 μV/m
(For the U.S.A., Canada and others)	
S/N 20 dB at 1000 kHz	500 μV/m

■ SPEAKER SECTION

Front, center and surround speakers (SB-AFC80)

Type	1 way 1 speaker Bass-ref.
Speaker unit	
Full range	8 cm (3-1/8") cone type
Impedance	6 Ω
Input power	
MUSIC	60 W
DIN	30 W
Sound pressure level	79 dB/W (1.0 m)
Frequency range	80 Hz–22 kHz (–16 dB) 110 Hz–20 kHz (–10 dB)
Dimensions (W×H×D)	88×158×105 mm (3-15/32"×6-7/32"×4-1/8")
Mass	0.8 kg (1.8 lb.)

Subwoofer (SB-W70)

Type	1 way 1 speaker Bass-ref.
Speaker unit	
Woofer	17 cm (6-3/4") cone type
Impedance	6 Ω
Input power	
MUSIC	180 W
DIN	90 W
Sound pressure level	80 dB/W (1.0 m)
Frequency range	42 Hz–1.5 kHz (–16 dB) 46 Hz–900 Hz (–10 dB)
Dimensions (W×H×D)	173×315×300 mm (6-13/16"×12-13/32"×11-13/16")
Mass	4.0 kg (8.8 lb.)

■ GENERAL (For the U.S.A. and Canada)

Power supply	AC 120 V, 60 Hz
Power consumption	190 W
Standby	0.25 W
Dimensions (W×H×D)	430×114×368 mm (16-15/16"×4-1/2"×14-1/2")
Mass	8.4 kg (18.5 lb.)

■ GENERAL (For Latin America and others)

Power supply	AC 110 V/127 V/220 V–230 V/240 V, 50/60 Hz
Power consumption	168 W
Standby	0.80 W
Dimensions (W×H×D)	430×114×368 mm (16-15/16"×4-1/2"×14-1/2")
Mass	8.4 kg (18.5 lb.)

Note:

- Specifications are subject to change without notice. Mass and dimensions are approximate.
- Total harmonic distortion is measured by the digital spectrum analyzer.

Warranty (Only for U.S.A.)

Panasonic Consumer Electronics Company,
Division of Matsushita Electric Corporation
of America
One Panasonic Way,
Secaucus, New Jersey 07094

Panasonic Sales Company, Division of Matsushita Electric
Corporation of Puerto Rico, Inc.
Ave. 65 de Infantería, Km. 9.5, San Gabriel Industrial
Park, Carolina, Puerto Rico 00985

Panasonic/Technics Audio Products Limited Warranty

Panasonic Consumer Electronics Company or Panasonic Sales Company (collectively referred to as "the warrantor") will repair this product with new or refurbished parts in the event of a defect in materials or workmanship, free of charge, in the U.S.A. or Puerto Rico as follows (all time periods start from the date of original purchase):

AUDIO PRODUCTS—labor and parts for one (1) year.

ALL AUDIO RACKS (cabinets)—parts only 30 days.

TECHNICS STAND ALONE SPEAKERS, SUBWOOFER SPEAKERS—labor and parts for three (3) years.

USB READER-WRITER, PERSONAL COMPUTER CARD ADAPTERS—(when applicable)—exchange defective unit with a new or refurbished one for one (1) year.

ACCESSORIES—HEADPHONES, CARTRIDGES, MICROPHONES, ADAPTERS—labor and parts for ninety (90) days.

RECHARGEABLE BATTERIES—(when applicable)—exchange defective item for new one for ten (10) days. Non-rechargeable batteries are not warranted.

SD MEMORY CARDS, RECHARGEABLE BATTERY PACKS—(when applicable)—exchange defective item for new one for ninety (90) days. Non-rechargeable battery packs are not warranted.

Carry-in or mail-in service in the U.S.A. can be obtained during the warranty period by contacting a Panasonic Services Company (PASC) Factory Servicenter listed in the Servicenter Directory. Or call toll free, 1-800-211-7262 to locate a PASC authorized Servicenter. Carry-in or mail-in service in Puerto Rico can be obtained during the warranty period by calling the Panasonic Sales Company telephone number listed in the Servicenter Directory.

This warranty is extended only to the original purchaser. A purchase receipt or other proof of date of original purchase will be required before warranty service is rendered.

This warranty only covers failures due to defects in materials and workmanship which occur during normal use and does not cover normal wear to the stylus (when applicable) or a dealer installed cartridge or stylus. The warranty does not cover damages which occur in shipment or failures which are caused by products not supplied by the warrantor, or failures which result from accident, misuse, abuse, neglect, mishandling, faulty installation, misapplication, set-up adjustments, maladjustment of consumer controls, improper operation or maintenance, improper antenna, inadequate signal reception or pick-up, alteration, modification, power line surge, improper voltage supply, lightning damage, commercial use, such as: hotel, office, restaurant, or other business or rental use of the product, or service by anyone other than a PASC Factory Servicenter or a PASC authorized Servicenter, or damage that is attributable to acts of God.

LIMITS AND EXCLUSIONS

There are no express warranties except as listed above.

THE WARRANTOR SHALL NOT BE LIABLE FOR INCIDENTAL OR CONSEQUENTIAL DAMAGES RESULTING FROM THE USE OF THIS PRODUCT, OR ARISING OUT OF ANY BREACH OF THIS WARRANTY, INCLUDING WITHOUT LIMITATION, DAMAGE TO TAPES, RECORDS OR DISCS. ALL EXPRESS AND IMPLIED WARRANTIES, INCLUDING THE WARRANTIES OF MERCHANTABILITY, AND FITNESS FOR A PARTICULAR PURPOSE, ARE LIMITED TO THE APPLICABLE WARRANTY PERIOD SET FORTH ABOVE. Some states do not allow the exclusion or limitation of incidental or consequential damages, or limitations on how long an implied warranty lasts, so the above exclusions or limitations may not apply to you.

This warranty gives you specific legal rights and you may also have other rights which vary from state to state.

If a problem with this product develops during or after the warranty period, you may contact your dealer or Servicenter. If the problem is not handled to your satisfaction, then write to the Consumer Affairs Department at the company address indicated above.

If you ship the product

Carefully pack and send it prepaid, adequately insured and preferably in the original carton. Attach a postage-affixed letter, detailing the complaint, to the outside of the carton.

Do NOT send the product to the Executive or Regional Sales offices. They are NOT equipped to make repairs.

Customer's Record

Model No. _____	Dealer's Name _____
Serial No. _____ or _____	_____
Code No. _____	Dealer's Address _____
Date of Purchase _____	_____

Panasonic

Technics

Quasar

*For Product Information, Operating Assistance, Literature Request, Dealer Locations, and all Customer Service inquiries please contact:
1-800-211-PANA (7262), Monday-Friday 9 am-9 pm; Saturday-Sunday 9 am-7 pm, EST.*

*Web Site: <http://www.panasonic.com>
You can purchase parts, accessories or locate your nearest servicenter by visiting our Web Site.*

Accessory Purchases:

1-800-332-5368 (Customer Orders Only)
Panasonic Services Company 20421 84th Avenue South, Kent, WA 98032
(6 am to 5 pm Monday-Friday; 6 am to 10:30 am Saturday; PST)
(Visa, MasterCard, Discover Card, American Express, Check)

Factory Servicenters Locations

<p>CALIFORNIA 6550 Katella Avenue Cypress, CA 90630</p> <p>800 Dubuque Avenue S. San Francisco CA 94080</p> <p>20201 Sherman Way Suite 102 Canoga Park, CA 91306</p> <p>3878 Ruffin Road Suite A San Diego, CA 92123</p> <p>COLORADO 1640 South Abilene Street Suite D Aurora, CO 80012</p> <p>FLORIDA 3700 North 29th Avenue Suite 102 Hollywood, FL 33020</p>	<p>GEORGIA 8655 Roswell Road Suite 100 Atlanta, GA 30350</p> <p>ILLINOIS 9060 Golf Road Niles, IL 60714</p> <p>1703 North Randall Road Elgin, IL 60123 (Pick-up/Drop-off only)</p> <p>MARYLAND 62 Mountain Road Glen Burnie, MD 21061</p> <p>MASSACHUSETTS 60 Glacier Drive Suite G Westwood, MA 02090</p>	<p>MICHIGAN 37048 Van Dyke Avenue Sterling Heights, MI 48312</p> <p>MINNESOTA 7850-12th Avenue South Airport Business Center Bloomington, MN 55425</p> <p>OHIO 2236 Waycross Road Civic Center Plaza Forest Park, OH 45240</p> <p>PENNSYLVANIA 2221 Cabot Blvd. West Suite B Langhorne, PA 19047</p>	<p>TEXAS 13615 Welch Road Suite 101 Farmers Branch TX 75244</p> <p>WASHINGTON 20425-84th Avenue South Kent, WA 98032</p>
			<p>HAWAII 99-859 Iwaiwa Street Aiea, Hawaii 96701 Phone (808) 488-1996 Fax (808) 486-4369</p>

Service in Puerto Rico

*Matsushita Electric of Puerto Rico, Inc. Panasonic Sales Company/Factory Servicenter:
Ave. 65 de Infanteria, Km. 9.5, San Gabriel Industrial Park, Carolina, Puerto Rico 00985
Phone (787) 750-4300 Fax (787) 768-2910*

Reference

THE FOLLOWING APPLIES ONLY IN THE U.S.A.

CAUTION:

This equipment has been tested and found to comply with the limits for a Class B digital device, pursuant to Part 15 of the FCC Rules.

These limits are designed to provide reasonable protection against harmful interference in a residential installation. This equipment generates, uses and can radiate radio frequency energy and, if not installed and used in accordance with the instructions, may cause harmful interference to radio communications. However, there is no guarantee that interference will not occur in a particular installation. If this equipment does cause harmful interference to radio or television reception, which can be determined by turning the equipment off and on, the user is encouraged to try to correct the interference by one or more of the following measures:

- Reorient or relocate the receiving antenna.
- Increase the separation between the equipment and receiver.
- Connect the equipment into an outlet on a circuit different from that to which the receiver is connected.
- Consult the dealer or an experienced radio/TV technician for help.

Any unauthorized changes or modifications to this equipment would void the user's authority to operate this device.

This device complies with Part 15 of the FCC Rules. Operation is subject to the following two conditions: (1) This device may not cause harmful interference, and (2) this device must accept any interference received, including interference that may cause undesired operation.

User memo:

DATE OF PURCHASE _____
DEALER NAME _____
DEALER ADDRESS _____
TELEPHONE NUMBER _____

The model number and serial number of this product can be found on either the back or the bottom of the unit. Please note them in the space provided below and keep for future reference.

MODEL NUMBER _____
SERIAL NUMBER _____

Apparatus Claims of U.S. Patent Nos. 4,631,603, 4,577,216, and 4,819,098, licensed for limited viewing uses only.

This product incorporates copyright protection technology that is protected by method claims of certain U.S. patents and other intellectual property rights owned by Macrovision Corporation and other rights owners. Use of this copyright protection technology must be authorized by Macrovision Corporation, and is intended for home and other limited viewing uses only unless otherwise authorized by Macrovision Corporation. Reverse engineering or disassembly is prohibited.

For the U.S.A.

Panasonic Consumer Electronics Company,
Division of Matsushita Electric Corporation of America
One Panasonic Way Secaucus,
New Jersey 07094
<http://www.panasonic.com>

Panasonic Sales Company,
Division of Matsushita Electric of Puerto Rico, Inc.
("PSC")
Ave. 65 de Infantería, Km. 9.5
San Gabriel Industrial Park, Carolina,
Puerto Rico 00985

For Canada

Panasonic Canada Inc.
5770 Ambler Drive, Mississauga, Ontario L4W 2T3
www.panasonic.ca

For Latin America

Matsushita Electric Industrial Co., Ltd.
Osaka 542-8588, Japan

For others

Matsushita Electric Industrial Co., Ltd.
Corporate Management Division for the Americas
Sales Office for North America
Tokyo Panasonic Sales Section
32nd Floor, World Trade Center 4-1, Hamamatsu-cho,
2-Chome, Minato-Ku, Tokyo 105-6132, Japan

Panasonic Marketing Europe G.M.B.H. Wiesbaden N.
(a Division of Panasonic Marketing G.M.B.H.)
Military Sales Department
6200 Wiesbaden-Biebrich, Hagenauerstr. 43 Germany

